



Standard

CHANGE-MAKERS, INC.

SYSTEM 200

**MODEL SC-5T
BILL
CHANGER
INSTALLATION
AND
INSTRUCTION
MANUAL**

INDEX

WARRANTY.....	SECTION I
INTRODUCTION.....	SECTION II
INSTALLATION.....	SECTION III
OPERATION.....	SECTION IV
SERVICE.....	SECTION V
SPECIFICATIONS.....	SECTION VI
ILLUSTRATIONS*	SECTION VII

* Should be viewed before reading this manual. Parts referred to in this manual will be identified in the illustrations.

SECTION I

STANDARD CHANGE-MAKERS, INC.

Indianapolis, Indiana

LIMITED PRODUCT WARRANTY

ONE-YEAR WARRANTY

Standard Change-Makers, Inc. ("Manufacturer") warrants each product of its manufacture to be free from defects in material and workmanship if properly installed according to Manufacturer's Installation Instructions and serviced and operated under normal conditions according to Manufacturer's instructions. No other promise or affirmation of fact concerning the products or description, sample or model of the products shall be construed as augmenting or supplementing this limited warranty, unless the nature of the same as a warranty is set forth in writing and attested by the signature of an authorized representative of Manufacturer.

Manufacturer's obligation under this warranty is limited to correcting without charge at its factory, or one of its company-owned service centers, any machine, components, or parts thereof (except light bulbs) which are returned to its factory, or one of its company-owned service centers (transportation charges prepaid) within one year after being put into service, examination of which must disclose to Manufacturer's satisfaction that the machine, components, or parts thereof were originally defective and for which the manufacturer has a properly completed Owners Warranty Registration Card on file.

Each machine shipped from the factory contains Owner's Manuals. Before shipping a machine, components or parts thereof to Manufacturer or one of its company-owned service centers for warranty work, the owner shall be certain of the source of difficulty could not be corrected by performing one or more of the procedures described in the Owner's Manuals. If Manufacturer or one of its company-owned service centers finds, in the sole discretion of each, that the source of difficulty could have been corrected by procedures contained in the Owner's Manuals, MANUFACTURER AND/OR THE COMPANY-OWNED SERVICE CENTERS RESERVE THE RIGHT TO MAKE THEIR REGULAR CHARGE FOR ANY WORK PREFORMED.

This warranty shall not apply to any of Manufacturer's parts or products which must be replaced because of normal wear, which have been subject to misuse, negligence, or accident, or which have been repaired or altered outside of Manufacturer's factory or one of its company-owned service centers, unless authorized by Manufacturer. Manufacturer shall not be liable for any loss, damage, or expense (including without limitation the loss of money caused by inadvertent machine dispense or by the use of counterfeit or bogus money) caused from or related in any way to the use of its products or from any other cause. No person, agent, dealer, or any other entity is authorized to give or alter any warranties on behalf of Manufacturer nor to assume for Manufacturer any other liability in connection with any of its products. Manufacturer reserves the right to make design and/or operational changes in its products or parts thereof without obligation to incorporate these changes in products previously produced.

THIS WARRANTY IS VALID ONLY IF AN OWNER'S WARRANTY REGISTRATION CARD IS ON FILE WITH MANUFACTURER. THIS WARRANTY SUPERSEDES AND IS GIVEN IN LIEU OF ALL OTHER EXPRESS OR IMPLIED WARRANTIES (WHETHER ARISING UNDER STATUTE, CONVENTION OR TREATY), INCLUDING WARRANTIES AGAINST INFRINGEMENT, WARRANTIES OF MERCHANTABILITY AND FITNESS FOR PARTICULAR PURPOSE AND WARRANTIES ARISING FROM COURSE OF DEALING OR USAGE OF TRADE. THE MANUFACTURER'S OBLIGATION TO CORRECT ANY MACHINE, COMPONENTS, OR PARTS THEREOF AS SET FORTH HEREIN ABOVE SHALL BE IN LIEU OF ALL OTHER REMEDIES. IN NO EVENT SHALL MANUFACTURER BE LIABLE FOR INCIDENTAL OR CONSEQUENTIAL DAMAGES.

Effective March 1, 1995

SECTION II

INTRODUCTION

The Standard Change-Makers (SC-5) Bill Changer is the most economical of our product line. It has the same quality and reliability as our top-of-the-line models.

The System 200 accepts and dispenses change for 1-5-10-20 dollar bills of American currency, 2-5-10-20 of Canadian currency or 10-20-50-100 peso notes in Mexican currency.

- A microcomputer in the MCU (Master Control Unit) selectively discriminates between denominations. The MCU also provides protection against bogus bills and controls the change dispensing functions.
- Plug-in circuits and assemblies are featured for fast field service.
- The coin hopper permits rapid bulk loading and dispensing of coins.
- A counter (non-resettable) gives the owner an audit for total dollar amount accepted.
- Heavy gauge steel cabinetry is used for security.
- Optional coin acceptor.
- Optional bill box lock.
- Optional coin dispense programming switches.* (For token dispensing applications.)

*Special Order Only

SECTION III

INSTALLATION INSTRUCTIONS

The Standard Change-Makers SC-5T Bill Changer is designed for wall mounting. Because the conditions of each location vary greatly, the exact method of installation must be the responsibility of the owner. To assure proper operation, the following guidelines should be observed.

LOCATION

- Ease of accessibility by customers.
- Proper height from the floor. Specifications for accessibility of the handicapped call for all controls, bill and coin insertion slots, and coin cups to be no higher than 48 inches (1220 mm) or no less than 15 inches (380 mm) from the floor.
- Full swing of the door when open to allow easy access for filling or emptying machine.
- Wall construction: For maximum security, it is recommended that the changer be installed on a wall made of cement block, brick, or other type of masonry.
- The mounting holes on the back of the changer will accommodate 1/2" diameter bolts.
- If it is preferable, a pedestal floor stand is available. The unit should be bolted to the pedestal stand and the stand should be bolted to the floor.

WARNING: CHANGERS MOUNTED ON PEDESTAL FLOOR STANDS ARE TOP HEAVY. The changer must be secured to a rigid, vertical surface as well as to the stand to provide complete security and stability.

NOTE: If the changer is to be secured to a floor-mounted post, the post should be embedded in concrete. It is recommended that the post be filled with concrete for strength. The changer should be attached to a steel plate which has been welded to the floor-mounted post. This steel plate should be approximately the same size as the back of the changer. This plate should have four 1/2 inch bolts with the heads welded to prevent removal. The changer can be attached to the plate with four nuts & washers.

CAUTION: We do not recommend welding the cabinet to any kind of mounting. Welding can cause unwanted warping of the cabinet as well as damage to the internal electronic components.

- Good lighting is recommended in the area where your changer is to be located, both for your customer's convenience and for added security.
- Accessibility of electrical power.

MOUNTING

- After the site for your changer has been determined and prepared, open the cabinet door of the changer and remove all packing materials, hopper shipping straps, and the note acceptor shipping brackets from inside the cabinet.
 - A. Use a 1/2 inch diameter bolts for mounting the cabinet (See Section VI for mounting hole locations).
 - B. Make sure the cabinet is level and the mounting surface is flat.
- **CAUTION:** Even a slightly uneven surface can cause cabinet distortion when the mounting bolts are tightened. This can cause the door to fit unevenly when closed. Should the mounting surface be uneven, it may be necessary to shim one or more of the cabinet corners.
- Be sure that the inside of the cabinet as well as all changer components (stacker, hopper, note acceptor, and power supply) are free of metal shavings and other debris.
- After mounting, replace any components that were removed. Do not replace the shipping clips.

ELECTRICAL HOOK-UP

WARNING: Never connect or disconnect cables with power on.

CAUTION: It is recommended that electrical connections be performed by a qualified electrician and that you should check the local building codes for compliance.

- It is recommended that 100V 60Hz AC wiring to the changer be installed on a dedicated line with an isolated ground wire (3rd wire) connected to the ground bus bar on the main service panel. A dedicated line is a circuit which has no other equipment connected on the same fuse or circuit breaker. The purpose of a dedicated line is to reduce the probability of electrical interference created by other equipment that utilizes large induction motors (pumps, compressors, etc.) which may cause the changer to malfunction. The changer is equipped with an electrical filter network to reduce noise on the 100V AC input line voltage. In order for this filter to function the machine must be connected to a **PROPER GROUND**. The ground can be checked by measuring the voltage between the white wire and the green wire of the incoming line cord. This voltage should never exceed 0.8 VAC.

NOTE: Additional surge protection is recommended in locations utilizing industrial machinery, i.e. factories. Surges generated from faulty or overloaded motors can exceed the changers internal suppression capabilities resulting in unnecessary down times. Contact your nearest Standard Change-Maker's Service Center for recommended models.

NOTE: TEMPORARY HOOK-UPS - Never allow access to the power plugs if using extension cord. Power cable feed should not exceed 100 feet in length.

NOTE: An improperly connected machine may void your warranty.

SECTION IV

OPERATION

Before turning the power on, make sure that your changer has a good electrical and safety ground. Improper grounding of the changer will cause erratic operation and will void the warranty.

- SYSTEM POWER ON/OFF SWITCH (Refer to Fig. 1) - The system power on/off switch as well as the non-resettable counter and circuit breaker are located in the power box which is mounted on the inside right wall of the cabinet. When machine power is on the on/off switch will be illuminated.

- FILLING THE HOPPER WITH COINS (Refer to Fig. 1) - The "OUT OF SERVICE WHEN LIT" light on the front of the machine will flash at one second intervals to indicate the need to fill the hopper with coins. Filling the hopper is a simple task. Your machine has been equipped with one of the following hopper models:

EXTENDED CAPACITY - The hopper may be removed and filled outside the machine or it may be left in the machine while filling with coins. To fill the hopper without removing the hopper from the machine, tilt the top of the hopper forward until the tilt stop contacts the cabinet door opening. For coins contained in a bank bag, grasp the neck of the bag and twist it to choke the mouth of the bag. Invert the bag and insert the neck of the bag into the top of the hopper. Slowly loosen the grip on the neck of the bag, letting coins feed down into the hopper. When possible, avoid allowing string that may have come loose from the coin bag to fall into the hopper.

JUMBO - This larger model is identical as above except it slides forward to front for easy filling.

- REMOVING THE HOPPER FROM THE CHANGER:

EXTENDED CAPACITY - In normal use the hopper is free to pivot for emptying but is locked to the shelf. A hopper may be completely removed from the machine if desired. The following simple procedure should be followed:

1. Turn off the power to the unit.
2. Open the hopper access door.
3. Locate the two connectors and cables which connect the hopper to the rest of the system and disconnect from hopper.
4. Lift the hopper from the locking base and remove from the changer.
5. To re-install the hopper reverse this order.

JUMBO - This model is identical as above except it slides forward to front and roller push buttons must be pushed in to release (Located in center of roller wheels).

- STACKER OPERATION WHEN FULL (Refer to Fig. 2) - When a stacker bill box becomes completely full, the changer will be disabled and will be unable to accept more money. The "OUT OF SERVICE WHEN LIT" light will be illuminated. To remove the bill box, you must first lift up on the bill box latch rod (See instructions on bill box front). With rod lifted, slide bill box forward until free of stacker/note acceptor. Remove bills from bill box. To replace, slide bill box into stacker/note acceptor until bill box latch rod is firmly seated.

NOTE: If you have the locking bill box option, first unlock the bill box and proceed as described above.

- REMOVING THE STACKER/NOTE ACCEPTOR (Refer to Fig. 2 & Fig. 3) - REMEMBER - Never connect or disconnect electrical cables with the power on. Unplug the hopper cord from J5 of the MCU Board. Remove the coin acceptor cord from either J1 or J6 (depending on which type of coin acceptor) and remove the power cord from J4 of the MCU Board. After releasing (lifting) the travel limit stop (that is located on the lower left side of the stacker opposite MCU side) slide the stacker/note acceptor out. To re-install the stacker/note acceptor, reverse this order.
- AUDITING THE MACHINE (Refer to Fig. 1) - Money received is counted by a highly reliable, non-resettable, electro-mechanical counter. One count for every denomination (e.g. \$1.00 = one count and \$5.00 = five counts).
- ROUTINE MAINTENANCE - See SECTION V.
- RESETTING A MACHINE ERROR - See Section V for error descriptions and machine reset sequence.
- HOPPER DUMP BUTTON - This button is located to the left of the DIP switches. When the hopper is in a sold-out condition and the button is pressed and released, the hopper will turn on momentarily indicating successful activation of the button. There will be a pause for few seconds so the user can support a bag or box under the hopper before the hopper turns on again.
- SYSTEM PROGRAMMING

There are two variations of the SC-5T: Change or Token. Either unit can accept any of four bills. The U.S. models will accept \$1, \$5, \$10 and \$20; Canadian models \$2, \$5, \$10 and \$20; and Mexican models \$10, \$20, \$50 and \$100 Peso notes.

The Changer model will allow you to deactivate individual bill acceptance by simply moving a switch. The Token model will also allow you to program the number of tokens to be dispensed for each denomination of bill.

Current production can accept either one of two different coin acceptors. J1 or J6 is used for the cable connection to the coin acceptor. J1 and J6 are two different sizes and the proper cable should fit easily into the correct connector. Do NOT force the connection.

TOKEN MACHINES - In the token changer version of the SC-5T, the bill acceptance and the amount of tokens dispensed for each denomination of bills are set by means of four pairs of rotary switches. These eight switches are arranged in two rows of four switches each and are located in the upper left corner of the MCU Board. The left most switch pair on the top row set the dispense amount for the \$1 (or \$2) bill. The top row, right pair sets the \$5 dispense, while the bottom row sets the \$10 (left pair) and the \$20 (right pair) dispense.

IMPORTANT: After changing the switches it will be necessary to momentarily turn power off to the machine and then back on (using the power box on/off switch) for the selection to be in effect.

To set the machine to reject a certain bill denomination, set both switches in that bill's switch pair to "0".

To set the dispense amount for each denomination accepted, the left switch of each pair sets the number of "10" units dispensed and the right switch sets the "1" units.

FOR EXAMPLE: To set the machine to dispense 4 tokens for a dollar adjust the first (left most) switch in the top row to "0"; the second switch to "4"; the third to "0" and the right most switch to "0". If all four switches in the bottom row are set to "0", the machine will not accept \$5, \$10 or \$20 bills and will dispense for a \$1 bill 4 coins from the hopper.

NOTE: The program calculates the token value based on the lowest denomination set for acceptance. Therefore, if the machine is equipped with a coin acceptor, a token will be dispensed when the amount of coins deposited reaches or exceeds the token value. Any monies in excess of this value are retained in escrow. The token value is rounded to the next higher nickel increment if the value is in odd cents, i.e., three for a dollar, or 33-1/3 cents each would be rounded to 35 cents each.

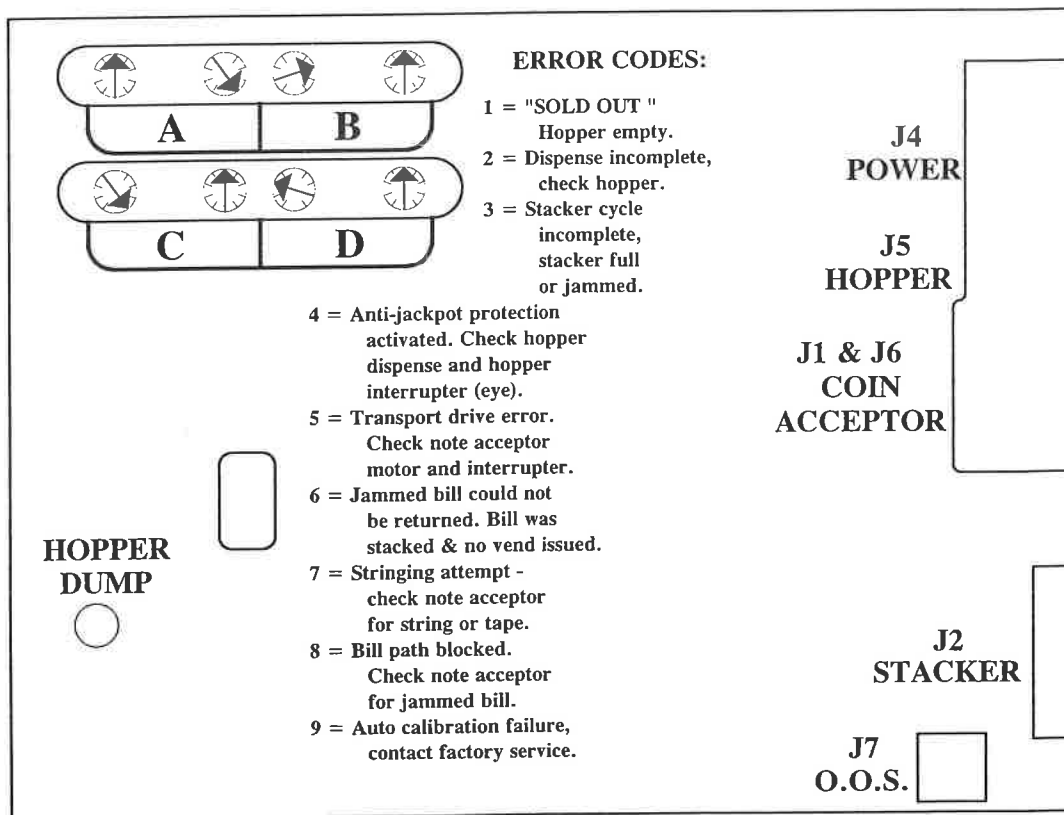

Token Machine

CHANGER MACHINES - In the Changer version of the SC-5T, the bill acceptance is turned on or off for each individual bill by a series of DIP switches. These switches are located at the upper left of the MCU board, starting with the \$1 (\$2) switch nearest the front edge of board. A bill is set for acceptance by activating it's switch to the up position.

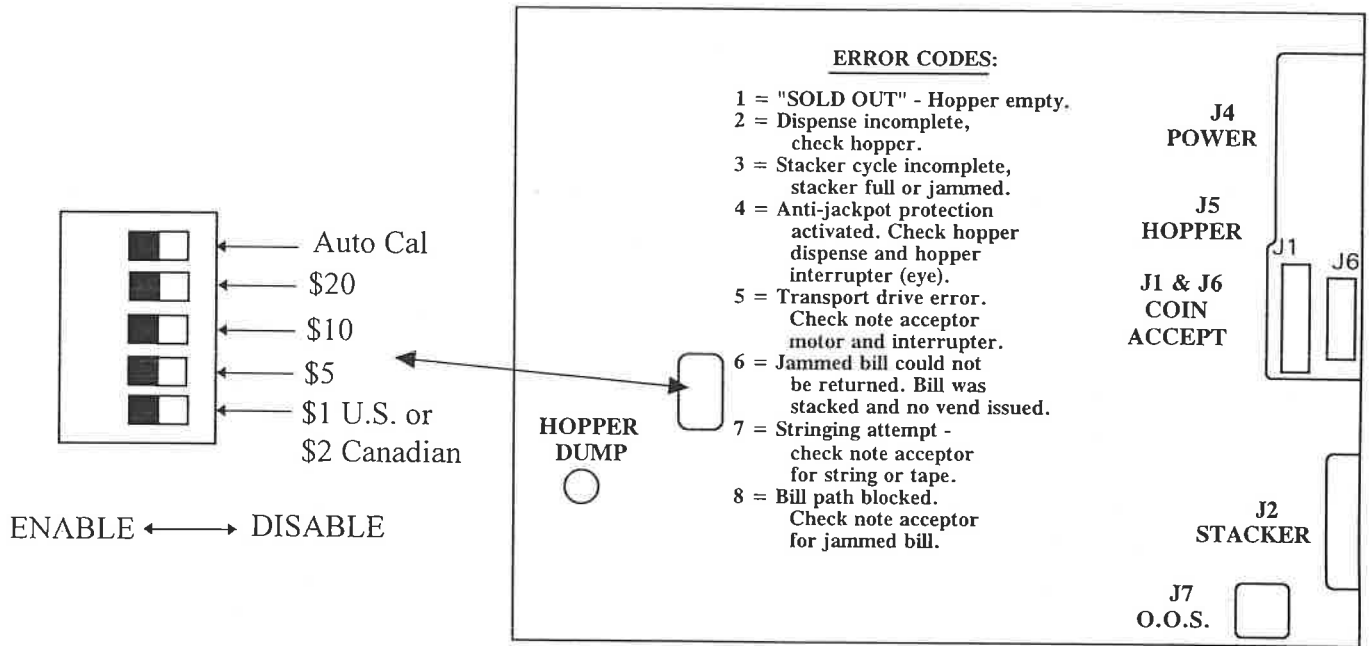

Changer Machine

The changer version of the SC-5T can now have bill acceptance turned on or off for each individual bill by a series of DIP switches. These switches can be accessed without taking the cover off. Moving the switch to the left will enable acceptance of that bill while moving it to the right will disable acceptance.

A hopper dump button is included on both the changer and token version of the SC-5T. This button is located to the left of the DIP switches. When pressed and then released the hopper will turn on momentarily and drop one coin as feedback to the user. There will be a pause for a few seconds so the user can support a bag or box under the hopper before the hopper turns on again.

SECTION V

TROUBLESHOOTING THE SYSTEM 200A

- **ROUTINE MAINTENANCE**

Stacker - (Refer to Fig. 2) The bill stacker requires little or no maintenance. Remove any bill or paper scraps if present.

Note Acceptor - (Refer to Fig. 1) The note acceptor upper and lower track sensors should be cleaned every three months or more often in the case of high volume locations.

Symptoms of dirty sensors

1. Poor acceptance of all denominations.
2. Note acceptor runs in reverse for long periods of time before taking bill in.

NOTE: Cleaning the track sensors - The track sensors can be cleaned or dusted using a soft bristle brush (included) or by using a low pressure air stream. Be sure the air is not contaminated with oil or water.

Hopper - (Refer to Fig. 1) Check the hopper for any debris from coin bags or wrappers.

Cabinet - Clean the cabinet with a damp cloth. If the machine is equipped with a coin acceptor check the coin reject button for proper operation. When pressed and released, the button should return on its own.

- **REMOVING A JAM FROM THE NOTE ACCEPTOR** (Refer to Fig. 4) - To remove a note jammed in the acceptor, a step-by-step procedure is given below. Please note the acceptor upper track is hinged so that the upper track section can be opened to expose the bill channel.

1. Lift up on the latch found on top of the acceptor to release the upper track section and pull upward to open the bill channel.
2. Remove the jammed paper from the bill channel.
3. Close the bill channel by pushing down on the upper track section until it is all the way down into the acceptor channel.
4. Fasten the latch and clamp securely.

- **USING THE LIGHTS FOR TROUBLESHOOTING** (Refer to Fig. 1)

1. MCU - During normal operation, this light should flash continuously. (Also used during calibration.)
2. PWR - Normally on - when off, this indicates the DC voltage is not adequate for proper operation.
3. INT - This light should flash once for each coin accepted. (Also used during calibration.)
4. HPR - This light is off when the hopper is empty.
5. COIN - This light should flash once for each coin accepted. (Also used during calibration.)

The System 200A has built-in self-diagnostic software for precise and efficient troubleshooting. These diagnostics indicate the source of error by a flash code sequence using the MCU lights as the indicator.

When the unit is in the “ready” mode (not stacking, dispensing, or accepting) the MCU status light will flash approximately ten times per second. When displaying an error code, the MCU light will flash a predetermined number of flashes, turn off for 1 second then repeat the flash code. When the problem has been resolved and the power is turned off, then on (a machine reset sequence) the error indicator will return to the “ready” status.

Error codes: Determined by number of flashes

1 = Sold Out

- Check - Hopper for correct level of coins.
- Hopper connectors. Are they secure?

2 = Dispense cycle incomplete

- Check - Hopper connectors. Are they secure?
- Hopper feed mechanism. Is something jamming the feed mechanism? To test, insert bill and listen for hopper motor to turn on. If motor is on but no coins are being dispensed, the feed mechanism is jammed. With power off, empty the hopper and check for bent coins or debris in the feed mechanism.

3 = Stacker ram cycle incomplete

- Check - Bill box. Is it full? If so, remove bills. See SECTION IV - OPERATION.
- Stacker compartment for the bill box. Remove jammed bills or debris from the stacker compartment.
- Stacker connector (J2). Is it secure?

4 = Anti-Jackpot* protection activated.

- Check - Hopper upon power up. Turn the power on/off switch to the “off” position (power switch not lit). Wait for three minutes before proceeding. After three minutes turn power switch to the “on” position (power switch lit red). If the hopper dispenses a coin, the hopper drive board is bad. Replace the board and test.
- Hopper interrupter (INT) light on MCU board. If the light is on, something is blocking the hopper interrupter (hopper coin counting eye) located inside the hopper access door. If nothing is blocking the hopper interrupter, replace it.

5 = Note acceptor transport drive malfunction.

- Check - Note acceptor motor connector. Is it secure?
- Note acceptor interrupter wheel (black plastic disc mounted to the motor shaft) and interrupter (eye that reads interrupter wheel) for proper alignment. The interrupter wheel should be centered in the interrupter.

6 = Something was inserted but the transport could not successfully reject it, i.e. an extremely limp or wet bill. The item was then transferred to the stacker and stacked. No vend was issued.

- Check - The note acceptor tracks. Is something blocking the bill path during a reject cycle?
- User confusion. If a bill is repeatedly rejected, some users will hold their hand over the bill port attempting to force the note acceptor to accept the bill. In this case, the note acceptor is unable to reject the bill. The bill will then be transferred to the stacker.

NOTE: This error when encountered will not cause an “out of service” condition.

* Jackpot is a term that means inadvertent machine dispense.

7 = Stringing attempt. Someone tried to extract a bill after it had been vended for.

Check - Note acceptor for strings or tape that may have been used. The bill tracks should be clear of debris before the machine is put back in service.

8 = Bill path blocked.

Check - Bill tracks for jammed bill. Release upper track latch and lift up on track. Inspect bill path.

9 = Auto Calibration failure. Contact your nearest Standard Change-Maker's Service Center.

10 = No bills programmed. The system has not been programmed to accept any bills.

Check - That the bills to be accepted are set correctly on SW9.

11 = Track open. The track on the note acceptor has been opened.

Check - That the upper track is locked in place.

- **AUTO CALIBRATION PROCEDURE** - The following notes are very important and should be followed every time you recalibrate your unit. This procedure should only be performed as a last resort to correct for poor acceptance. Prior to this, please make sure that all sensors on the lower track are clean and that the verifier mounting and upper track are latched and positioned properly. If poor acceptance is still experienced, follow the procedure below:

1. Turn power OFF.
2. Write down the current settings of SW9 so that you can return to these same settings after you auto calibrate your unit.
3. Set the top switch of SW9 as shown in Figure 1; do not alter any other switch setting.
If this should occur refer to the settings written down in step 2.

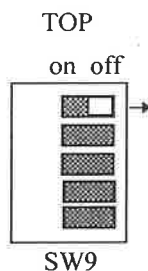

Figure 1

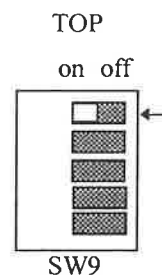

Figure 2

4. Turn power ON.
5. Change SW9 to the setting in Figure 2.
6. Insert calibration card.
7. Auto Calibration Sequence will occur at this point. If the card is not automatically ejected in approximately 2 seconds or less auto calibration has failed. If this occurs contact the Standard Change-Makers Service Department nearest you.
8. If the card is ejected in approximately 2 seconds or less auto calibration has taken place. Turn off power and move top switch of SW9 to the OFF position.

CALIBRATION NOTES:

- Never use a balance card more than once. Dispose of the balance card after one use.
 - Store unused balance cards in a cool dry area out of direct sunlight.
 - Never store unused balance cards for more than one year.
 - Once the balance card sequence has been started, do not change any DIP switch settings until the calibration sequence is finished and the card is ejected.
 - Always perform calibration at room temperature (70°-80° F) regardless of indoor or outdoor use. Failure to do so will result in improper calibration and poor acceptance/security
-
- **CONNECTORS** - Before disconnecting any cables the system power must be turned off. Some of the connectors have locking tabs which hold the separate sections together.
-
- CAUTION:** Before attempting to separate the two sections of the connector, make sure the locking tab has been depressed. If not, wires in the cable may break. Failure to release the tab prior to removing the cable can result in broken or intermittent electrical connections.

SECTION VI

SPECIFICATIONS

Measurements:	Height - 28" Width - 16-3/4" Depth - 12-1/4"
Weight:	Empty - 125 lbs. Loaded - 165 lbs.
Power:	105 to 125 volts AC, 60Hz
Operating Environments:	Indoor 32° F to 160° F
Capacities:	Stacker - 800 bills Hopper - 4,000 quarters 3,200 dollar coins (optional to use)

For additional information and assistance, please contact:

Standard Change-Makers

National Sales/Service Office
3130 North Mitthoeffer Road
P.O. Box 36550
Indianapolis, Indiana 46236-0550
Telephone: (317) 899-6966
FAX: (317) 899-6977

SECTION VII

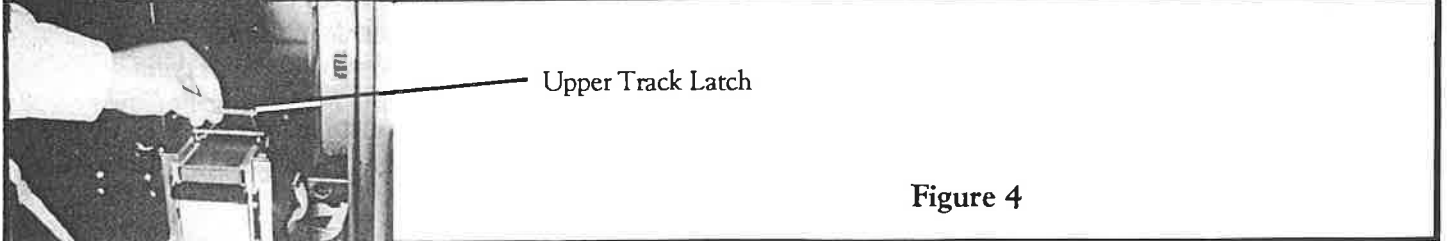
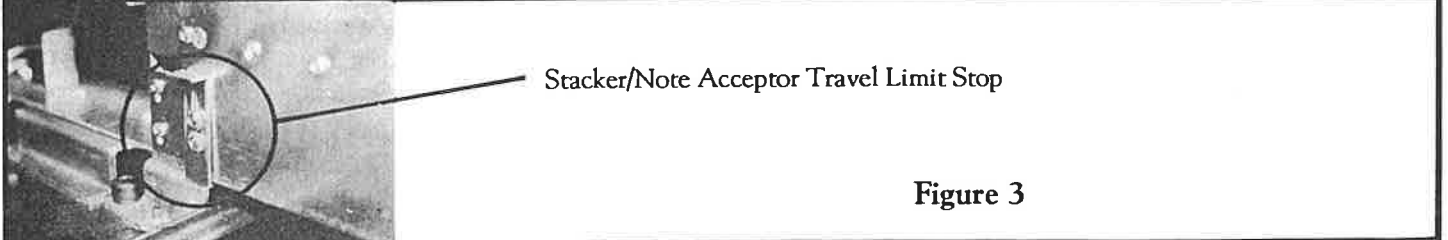
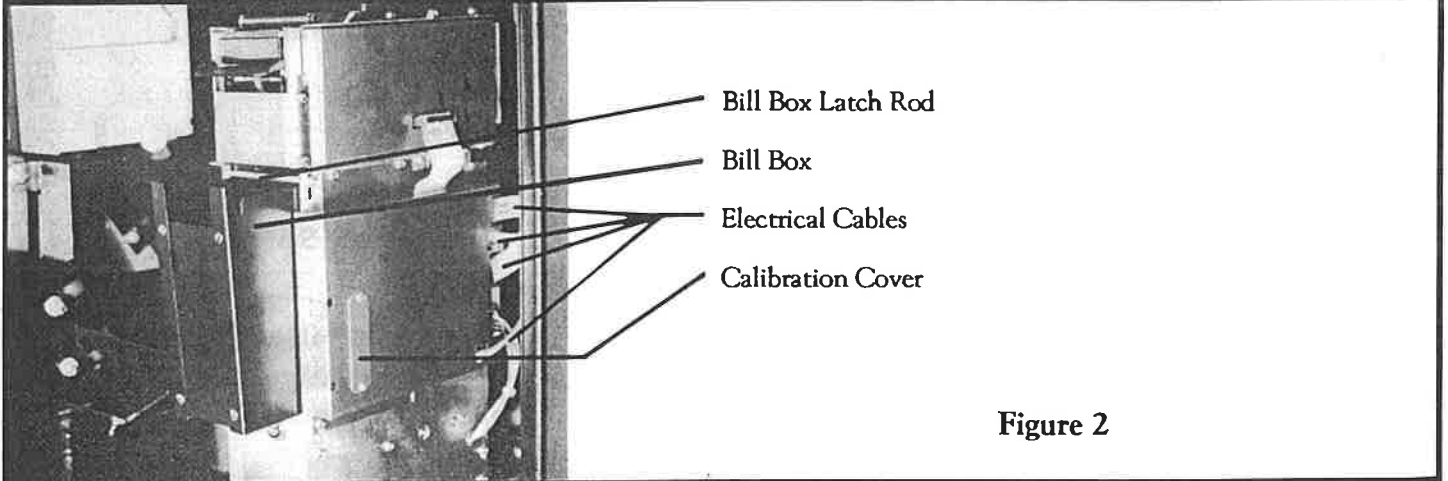
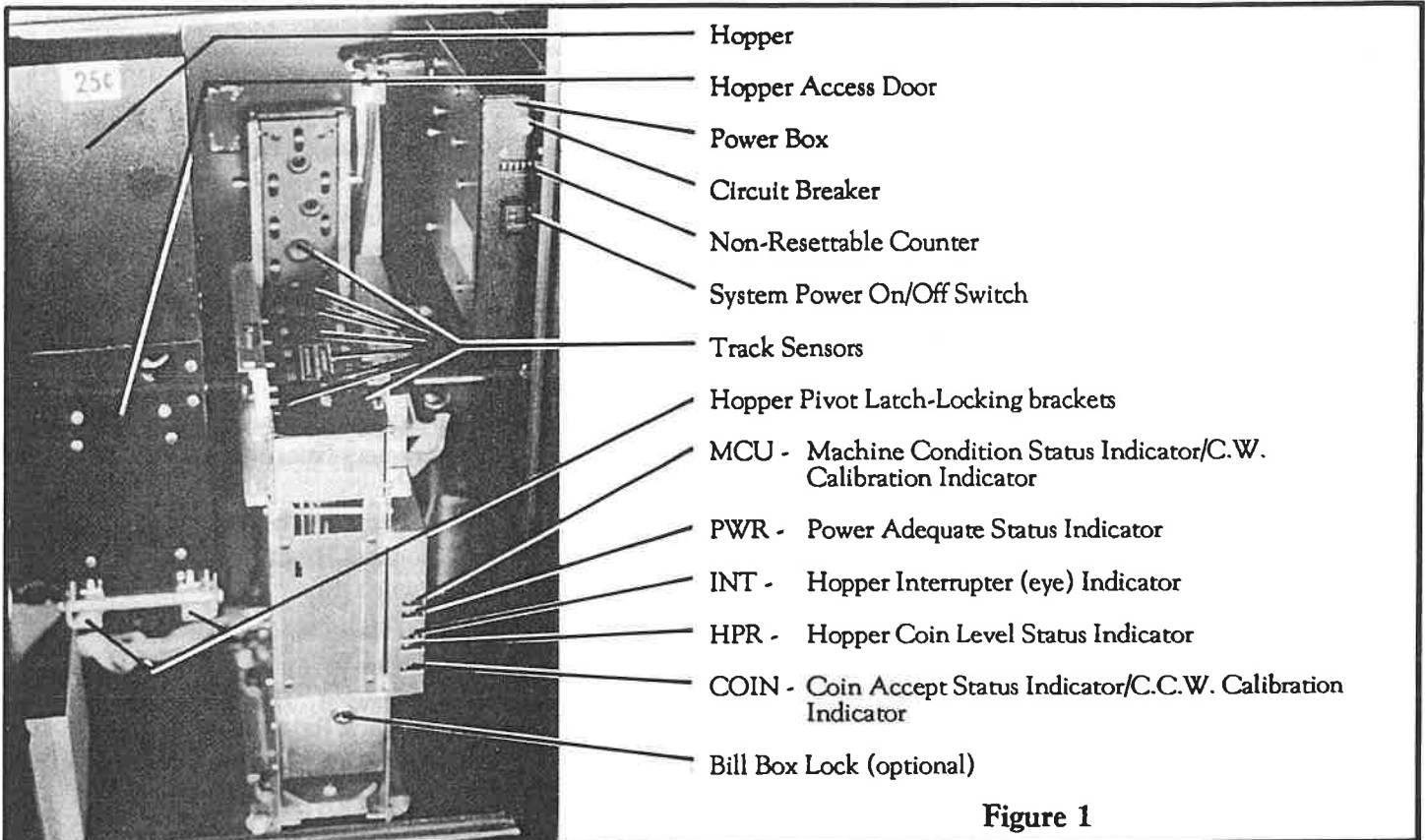

Parts List

Item #	Part #	Description
1	2P33974-U.S.	Currency Spacer Left
	2P33972 - Can.	
2	2P33973 - U.S.	Currency Spacer Right
	2P33971 - Can.	
3	2P33452	Security Gate
4	2M32553	Single-Drive Roller
5	1M00106	Note Acceptor Motor (12VDC)
6	2M32564	Main Drive Roller
7	4A00231 - U.S.	Lower Track Assembly (w/flex)
	4A00155 - Can.	
8	2F00823	Note Acceptor Chassis - Encoder side
9	2F00840	Interconnect Board Cover
10	2P34090	Strike
11	2F00822	Note Acceptor Chassis - Motor Side
12	4E00230	Interconnect Board
13	2P33530	Reference Clip
14	4E00147	Upper Track Flex Assembly
15	2F00839	Geartrain Cover
16	2F00863	Note Acceptor Track Extension
17	2F00174	Upper Track Retainer
18	2F00408	Upper Track Cover
19	2M33583	Creasing Drive Roller
20	2F00516	Stacker Side - Non Board
21	2F00185	Stacker Side - MCU
22	2F00853	MCU Cover
23	2F00178	Stacker Back
24	2F00128 - U.S.	Receiver
	2F00139 - Can.	
25	2F00129	Ram
27	2B00106	Ram Bearing Surface
28	2F00141	Carriage
29	2F00140	Motor Mount
30	1M00102	Stacker Ram Motor (12VDC)
32	4M00157	Crank Assembly
35	2P39260 - U.S.	Receiver Base
	2S33550 - Can.	
36	2F00179	Stacker Stop
37	4M00229	Bill Box Assembly
38	2F00177	Bill Box Shelf
39	1S00120	In Place Switch
40	5L00102	Bill Box Lock (Optional)
41	4E00218	Security Sensor Board Assembly
42	4E00217	Security Emitter Board Assembly
43	4M00228	Stacker Platform
44	4E00232	MCU Board - Changer Version
	4E00233	MCU Board - Token Version
45	2S00401	Calibration Potentiometer Cover
46	2F00191	Stacker Travel Limit
47	4C00127	Stacker Harness Assembly
48	2M34220	Idler Gear Axle

Mounting Hole Locations

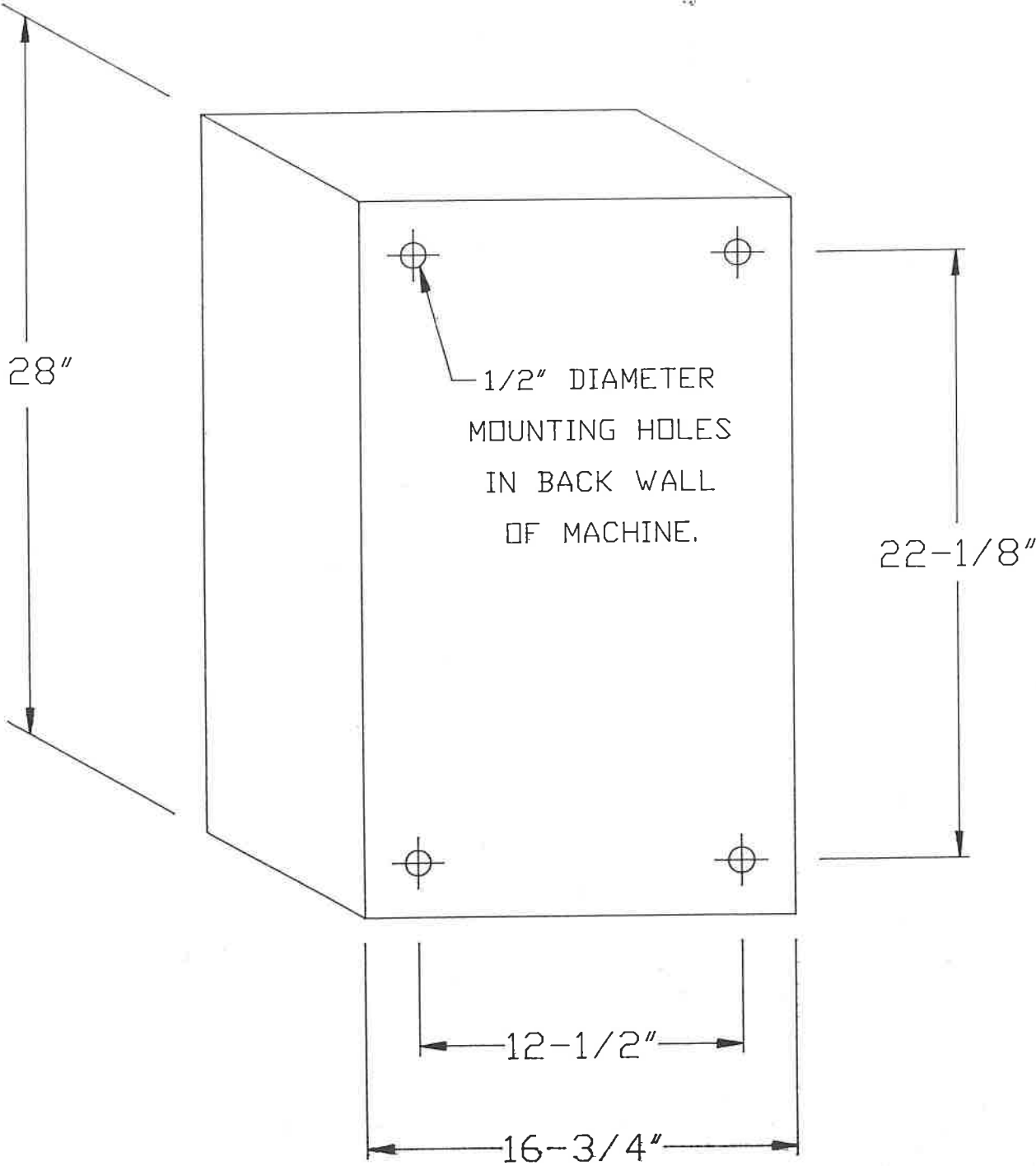

8M00267A
SYSTEM 200A
ASSEMBLY

