



**Standard**

Change-Makers

A DIVISION OF

**RKU** Standard Incorporated

3130 North Mitthoeffer Road  
Indianapolis, IN 46235-2400

Phone: 317-899-6966

Toll Free: 1-800-968-6955

[www.standardchange.com](http://www.standardchange.com)

# GUARDIAN XP (GXP)

**Installation Guide**

8M00551 Rev. 6



## TABLE OF CONTENTS

1. Environmental Considerations	Page 2
2. Ventilation	Page 3
3. Heating & Cooling Considerations	Page 4
4. Conduit and Cable Requirements	Page 5
5. Power and Surge Protection	Page 6
6. Cabinet Mounting Preparation	Page 8
7. GXP Stand Preparation/Installation Diagram	Page 12
8. GXP Island Preparation/Installation Diagram	Page 13
9. Wash Bay Connections	Page 14
10. Wash Bay Signal Timing	Page 16
11. Check the Programming – Navigating the Main Menu	Page 17 Page 22
12. GXP Main Menu Mode Program Loop	Page 23
13. Testing the Machine	Page 24
14. Troubleshooting	Page 25
15. Credit Card Settings	Page 26
16. PHOTOS – GXP	Page 29
17. Coin Acceptor – Slug Buster	Page 31
18. Bill Acceptor – CPI T7 Talos	

GXP Car Wash Entry Systems designed and manufactured by:

Standard Change-Makers  
Div. of RKU Standard Incorporated  
3130 N. Mitthoeffer Road  
Indianapolis, IN 46235  
[www.standardchange.com](http://www.standardchange.com)

Made in U.S.A.

## SECTION 1 – ENVIRONMENTAL CONSIDERATIONS

### BRICK OR BLOCK ENCLOSURE CONSIDERATIONS

The cabinet is designed to withstand direct exposure to the elements; however, it is recommended to provide additional protection. Enclosing the machine in a brick or block island is advisable as it enhances protection from the elements, increases security, and extends the equipment's longevity. Electrical equipment shielded from direct exposure on all sides (except the front) requires less maintenance and offers greater reliability throughout its service life. When installing the cabinet in a brick enclosure, it should be recessed 2 to 3 inches inside the block. This recess provides extra rain protection for the front of the machine and prevents vehicle mirrors from contacting the bezels on the machine's front.



### FREE-STANDING CABINET ON BASE CONSIDERATIONS

The cabinet can be mounted on a stand and exposed to the direct elements; however, it is advisable to provide some protection. Covering the machine with a canopy is recommended for stand-mounted cabinets. Consideration should be given to the cooling, rain protection, and heat barrier provided by the brick or block enclosure, as it significantly reduces the environmental extremes that the electronic components are exposed to in certain climates.

If the machine is directly exposed to the sun/summer heat or cold air in winter, it is critical to provide adequate heating and/or cooling protection. Free-standing machine



installations typically expose the cabinet on all sides to the elements, making it essential to include the necessary heating and cooling kits for these installations.

## SECTION 2 – VENTILATION FOR ISLAND STRUCTURES

### REASONS FOR PROPER VENTILATION

- 1) Extend the operating life of the electronic components in the machine.
- 2) Extend the operating life of the “thermal” paper used in the receipt printer.
- 3) Allow proper operation in Extreme Heat/Humidity environments found in the Southeastern and Extreme Heat of Southwestern states during the summer.

### GENERAL CONSIDERATIONS FOR VENTING:

- 1) Leave room behind the cabinet to allow air from the top, side and bottom island ventilation duct to flow freely into the machine.
- 2) To prevent bay mist from entering the machine, do not locate an intake vent in the enclosure on the side closest to the wash bay.

As shown in **Figure 1** – the brick enclosure has three possible vent locations that will allow air flow into the cavity of the enclosure and thereby allow air flow into the machine (FOR ILLUSTRATION PURPOSES).

**TOP VENTILATION** – If the “Beauty Ring” is used, the air will flow in from the top of the ring. If it is not used leave an air gap that will allow the air to enter. If this method is used on an island, be sure the island topper will prevent water from entering the vent area.

**SIDE VENTILATION** – If this method is used a “rain louver” should be included to prevent water from entering the island.

**BOTTOM VENTILATION** – Avoid placing at very bottom of island to prevent water from entering a brick island or enclosure that is susceptible to standing water. Locate up from bottom of island a minimum of one brick height or 4 inches (if possible).

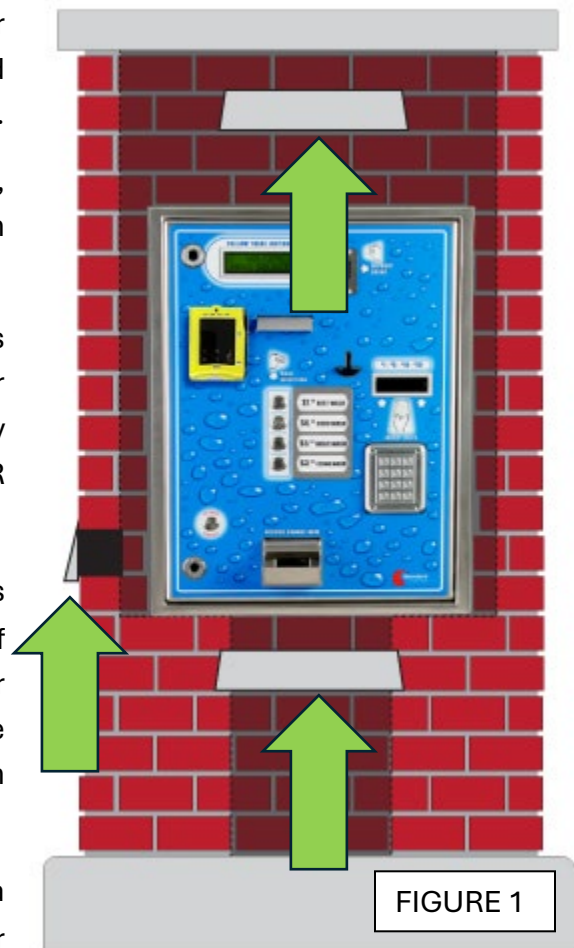

## SECTION 3 – HEATING AND COOLING CONSIDERATIONS

### HEATER KIT

The optional 280-watt Strip Heater Kit (Part #4K00910-PI) is thermostatically-controlled and activates when the internal temperature of the machine drops below 65°F.

**PLEASE NOTE:** It is important to remind the machine owner to close the air intake vents before the start of the cold weather season to prevent warm air from escaping through the intake vent.



### COOL AIR INTAKE

The optional Intake Fan (Part #4K00978-PI) is located on the back wall in the upper right corner. Check the filter, fan, and thermostat operation before and during the warm weather season. A dirty or clogged filter will reduce the effectiveness of the intake fan. A malfunctioning fan or thermostat will prevent the intake fan kit from mitigating excess temperature buildup inside the cabinet on warm, sunny days.

Keep the intake fan filter clean and free of dirt and bugs. The filter, located on the front of the intake fan (inside the cabinet), prevents bugs and heavy dust particles from entering the machine.

**PLEASE NOTE:** Remind the machine owner to open the intake fan port (as mentioned in Section 2) before the start of the warm weather season to allow cooler air to enter the cabinet.

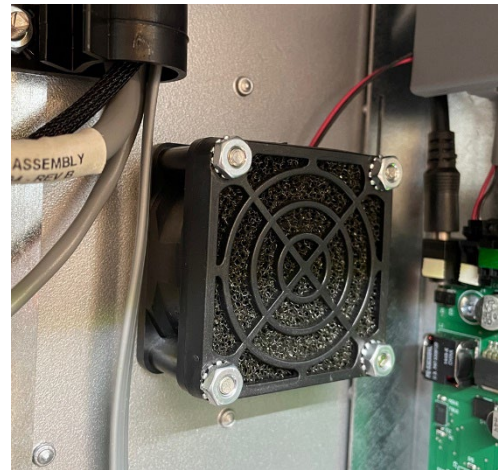

## SECTION 4 – CONDUIT AND CABLES (WASH BAY to GXP)

### CONDUIT RUN RECOMMENDATION

Standard Change-Makers recommends a minimum of **three (3) conduit runs** from the Wash Bay Equipment to the GXP pay station. These three would be for:

1. **POWER** – 1 CONDUIT for machine power
2. **DATA** – 1 CONDUIT for all data lines (Ethernet, Alarm, CC Camera, other communication requirements)
3. **BAY WASH EQUIPMENT CONNECTIONS** – 1 CONDUIT for wired connections including: Wash Selections 1, 2, 3, 4, Common, and Inhibit Relay.

If using upsell or other Wash Selection buttons 5, 6, 7, 8 – these should be included in this conduit run as well.

**PLEASE NOTE:** If DATA and WASH BAY CONNECTIONS terminate in the same junction box in the Control Room, then only one conduit run would be needed for both Data and Wash Bay Connections.

### CONDUIT TYPE RECOMMENDATION: ¾” PVC

#### POWER CONDUIT:

THREE (3) STRANDED 12-14 AWG WIRE (GROUND/NEUTRAL/HOT)

#### WASH BAY EQUIPMENT CONDUIT:

AT LEAST NINE (9) STRANDED 16-18 AWG WIRE (5 for WASH SELECTIONS 1-4, COMMON), (2 for INHIBIT) and (2 for OPTIONAL BAY OUT OF SERVICE LINE). **It is always a good idea to run extra wire for future upgrades (additional selections), or in case a wire breaks or stops working in the future.**

#### DATA COMMUNICATIONS CONDUIT:

This conduit run requires TWO (2) ETHERNET (CAT5/6) CABLES; one for the EF-4 Control Board and one for the credit card system (if using high-speed IP communication with the Nayax VPOS Touch). Additional cable runs may be needed for the alarm system, closed-circuit security cameras, RFID interface cables, etc.

The GXP EF-4 features an Ethernet port that connects the control board to an IP router via a CAT5/6 cable. This setup allows the GXP to send daily audit reports and out-of-service alerts. Note that remote access to the machine is not possible through this connection. Ensure this Ethernet cable is separate from the one used by the credit card system.

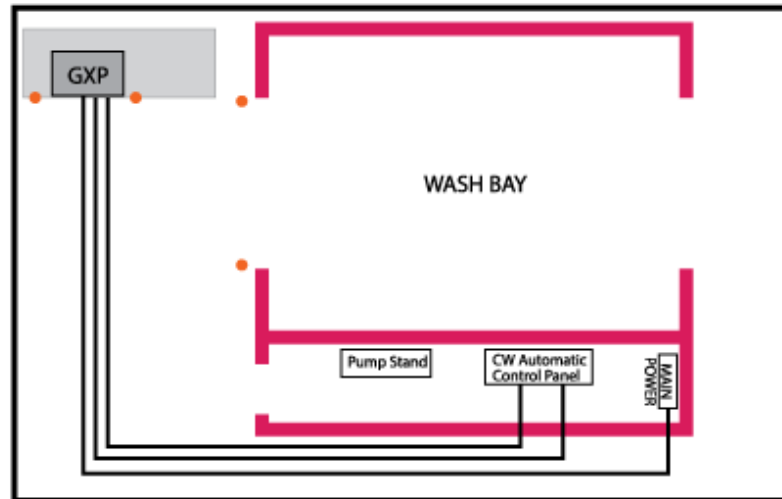

THE ABOVE DIAGRAM SHOWS AN EXAMPLE OF THE THREE CONDUIT LINES RUN FROM THE UTILITY ROOM TO THE GXP PAY STATION. TWO CONDUIT RUNS FROM THE WASH BAY EQUIPMENT CONTROL PANEL AND ONE FROM THE MAIN POWER PANEL.

## SECTION 5 – POWER AND SURGE REQUIREMENTS

### POWER REQUIREMENTS

The GXP Pay Station requires a 120 VAC power source capable of supplying at least 5 amps of current. The pay station itself needs about 1 amp, while the optional heater kit requires up to 2 amps. Additional items, such as a scrolling or backlit message sign, will require up to 1 amp.

For installation, we recommend using 12-gauge outdoor-rated wire with a third-wire ground. A dedicated line and circuit breaker from the main power panel are necessary. The main circuit breaker should be a 120 VAC – Single Pole Breaker rated for 10 or 15 amps.

### POWER CONNECTION

The power connection for the GXP is located at the bottom of the back wall behind the coin hopper platform. During installation, remove the coin hopper(s) and platform by disconnecting the cables to the Hopper Boards, tilting the platform forward, and lifting it from the bottom. **Remove the platform by taking off two nuts on the right side and loosening two nuts on the left side.**

With the platform removed, you will have easy access to the junction box at the back base of the cabinet and the conduits entering the bottom of the cabinet. Connect the three wires to the terminal in the Junction Box, as shown in the picture below, then reattach the cover with the two screws.

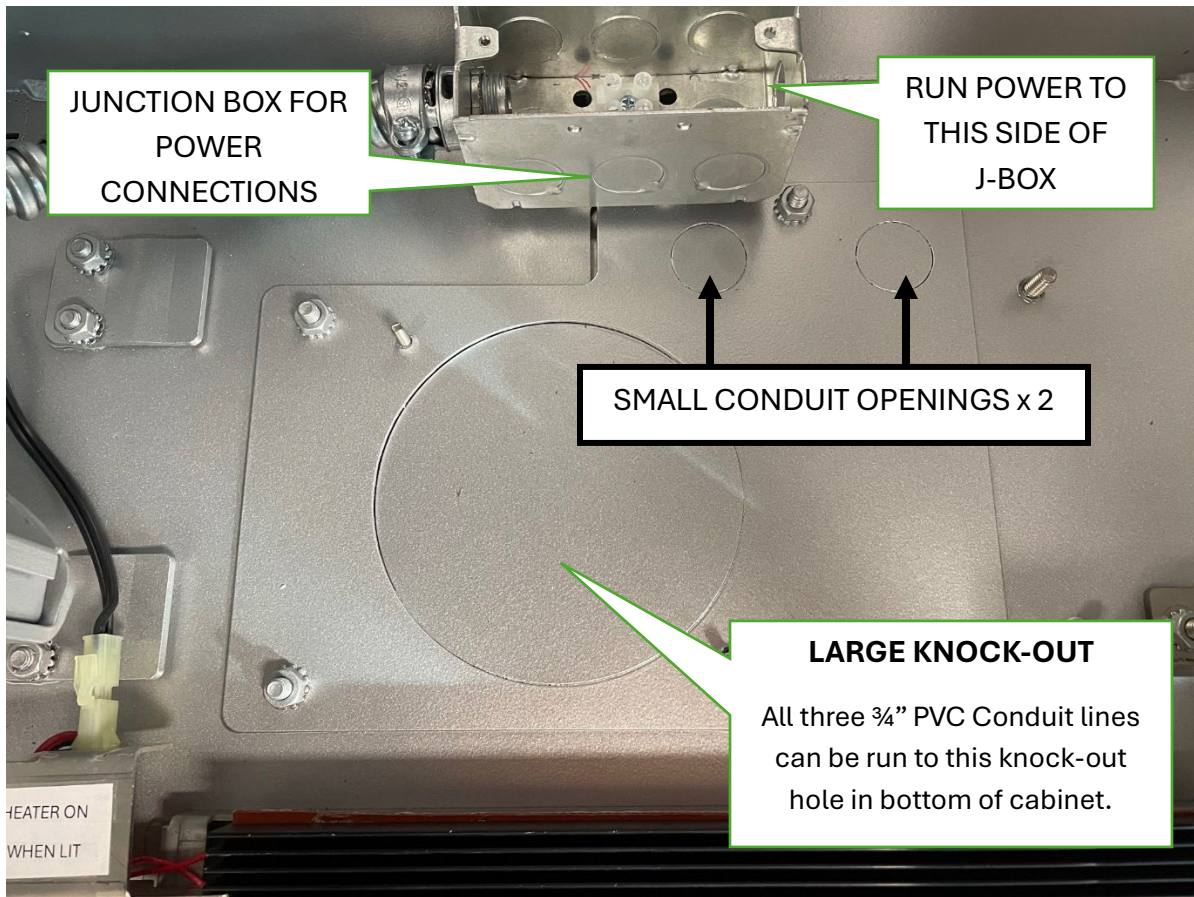

**PHOTO:** Bottom of the GXP Pay Station – Knocks Outs

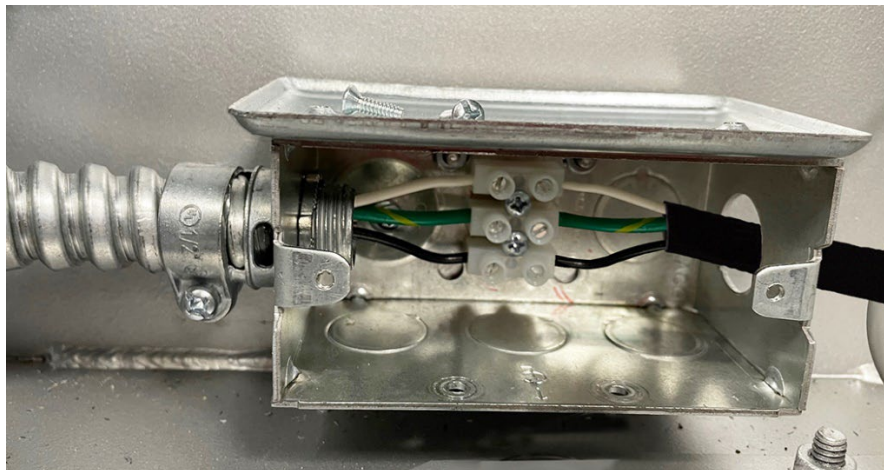

**PHOTO:** Power Connections to the GXP inside Junction Box. Hot, Neutral and Ground connected to the corresponding wires coming from the Power Supply Box.

Outdoor -Rated Power Supply for  
Hoppers & Bill Acceptor



**Secondary Power Box**  
with Main ON/OFF  
Switch

### **POWER BOX NOTE:**

On the left side of the GXP, you will find a **Secondary Power Box** with a red ON/OFF toggle switch and three grounded plug-ins. Please do not access this box! Make your power connection in the Junction Box as described above. The Secondary Power Box also includes an RFI filter for incoming line noise protection.

### **Surge Protection:**

Please note that damage to equipment caused by power surges and lightning strikes is not covered under warranty. If the machine is installed in an area prone to power surges or lightning, it is advisable to take additional precautions to protect the machine's internal components.

Recommendations include:

- Connecting the machine frame to a Ground Rod located at or near the machine using a heavy-gauge wire.
- Installing a High Energy Surge Protector on the power line entering the machine.

## **SECTION 6 - CABINET MOUNTING PREPARATION**

The robust design of the GXP allows it to be installed in a variety of mounting methods. Each method will require different considerations and planning.

Please review all available mounting kits (in this manual) before proceeding with the installation. The following steps apply to prepare the cabinet for any of the mounting options.

**1. IDENTIFY THE MOUNTING METHOD -**

Determine which mounting method is to be used (Free-standing or Island Mount in masonry, stucco, or steel enclosure), and make sure you have the correct mounting kit and parts.



**2. ANCHORING THE CABINET** - We recommend that the cabinet be anchored using as a minimum of four anchoring bolts in the corresponding holes in each corner of the base. To ensure that the cabinet is stable and secure use all four mounting holes inside the cabinet as well. There is a copy of the mounting base on Page 12 for your reference. and anchoring it on each side and the bottom of the cabinet. **Use hardened bolts and large washers for added strength.**

**IMPORTANT NOTE:** You must remove all electrical components from the machine prior to any welding. The heat and electrical surges can damage these components!

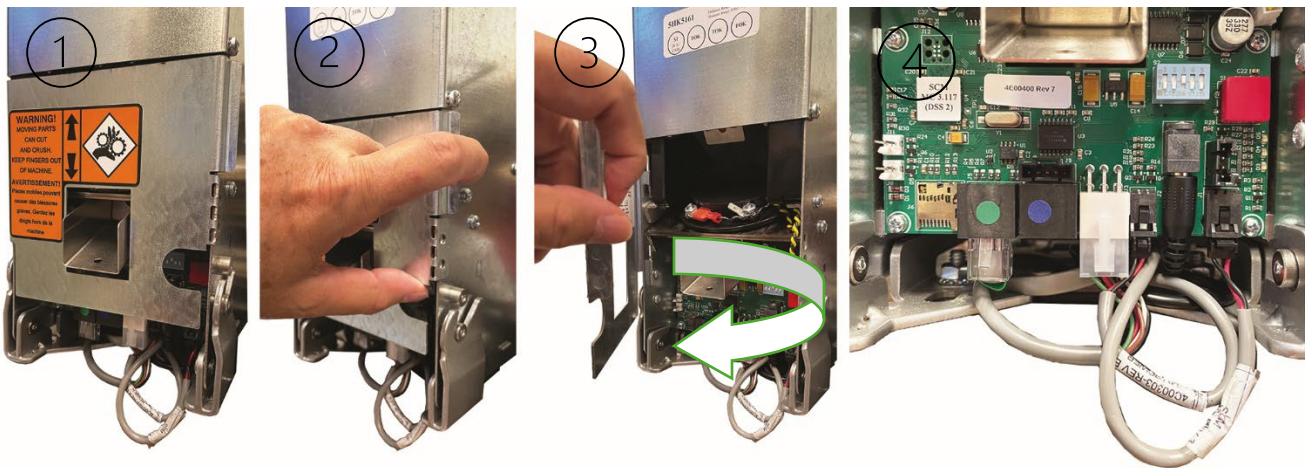

**1) Access Door on MC Hopper. 2) Pull tab on RIGHT side of Hopper Door. 3) Pull Door to the Left to access the hopper & cables. 4) Proper connections of cables to hopper**

**1) REMOVING THE COIN HOPPERS** - The coin hoppers have been installed and programmed prior to shipping. This will allow them to be removed and re-installed after the mounting process without losing programming. It is important to remember to plug the

coin hopper connections properly into the hopper(s) after they have been reinstalled. If your machine is equipped with the optional 2<sup>nd</sup> hopper then only the power and data COMM cables will be connected to the optional hopper.

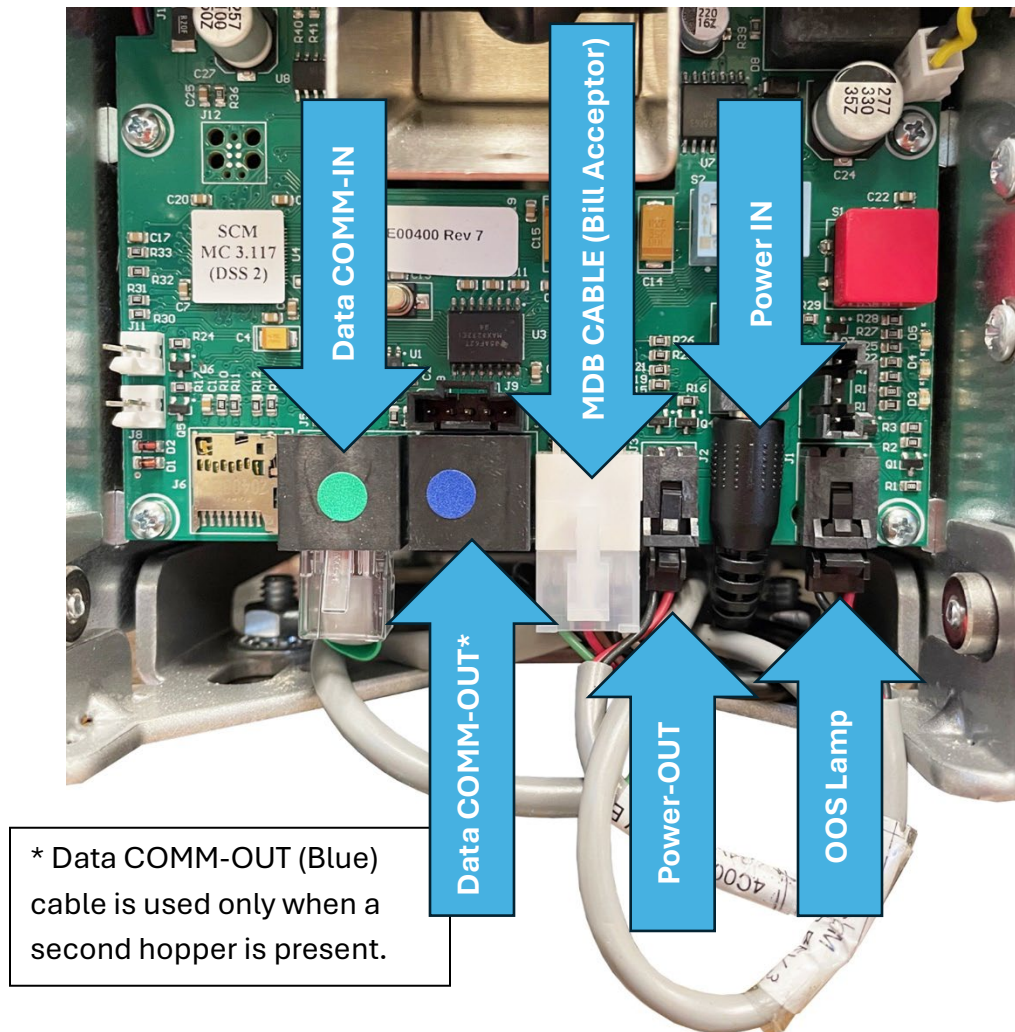

See the picture above for the correct connections. The Data COMM cables have been color-coded for ease of identification (BLUE/GREEN) as well as the Hopper control board connections show the identifying blue/green ports.

- 2) **REMOVE THE HOPPER PLATFORM** – To allow additional access to the bottom of the cabinet you must remove the hopper mounting platform. Remove the nuts that secure the hopper mounting platform and remove the platform.

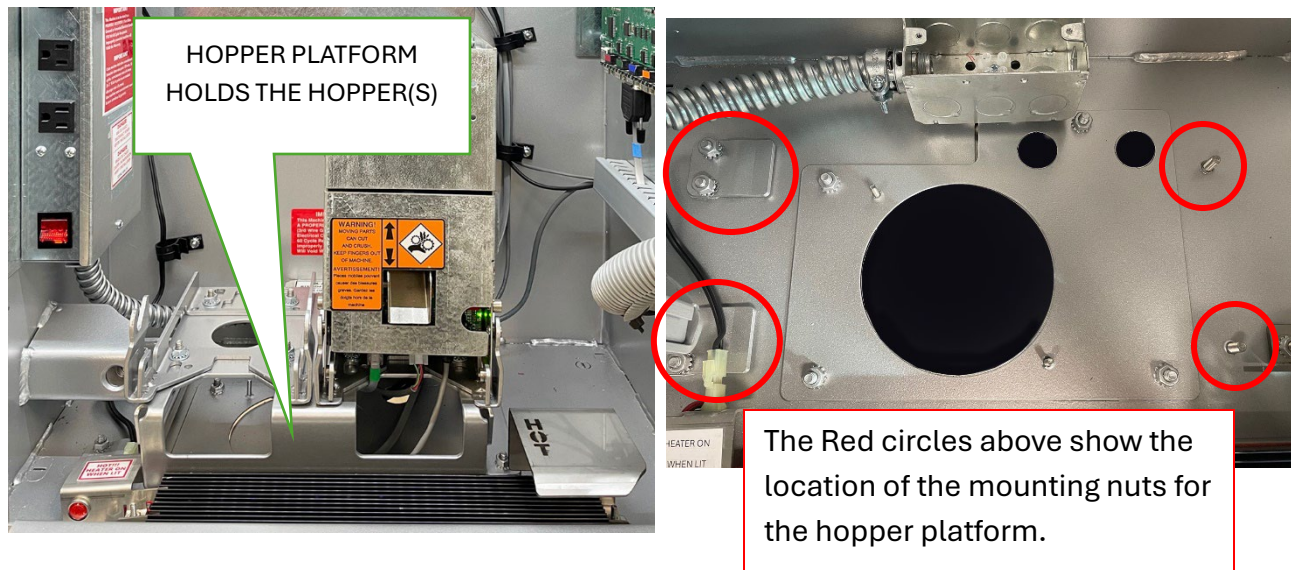

- 3) **REMOVE THE KNOCK-OUTS** - The cabinet includes a variety of access holes for the electrical connections (wash bay connections, power connections, data connections...) These can be removed using a large screw driver, small pry bar and a hammer if necessary. **The holes are available as individual conduit-sized holes or as a large hole that will allow easy access for all connections to enter machine.** The access holes are typically on the bottom of the cabinet while the Retrofit GXP model includes additional holes in the back of the cabinet for ease of alignment to existing conduits (especially designed for installation in a masonry enclosure).

## SECTION 7: FREE STANDING CABINET INSTALLATION (BASE MOUNTING)

Standard Change-Makers sells four mounting bases for free-standing applications:

### PAINTED CABINET AND PAINTED BASE (FREE STANDING)

- 26" PAINTED GXP BASE (for surface-level installation)
- 20" PAINTED GXP BASE (for curb-level installation)

### STAINLESS STEEL CABINET AND PAINTED BASE (FREE STANDING)

- 26" STAINLESS STEEL GXP BASE (for surface-level installation)
- 20" STAINLESS STEEL GXP BASE (for curb-level installation)

**Please see the Surface mount and Curb-Mount diagrams below for more information.**

**The image at the bottom of the page can be used to locate anchor bolts for the GXP Bases.**

# GXP - CURB MOUNTING and SURFACE MOUNTING ON STEEL BASE

SURFACE MOUNTED (26" Base)

CURB MOUNTED (20" Base)

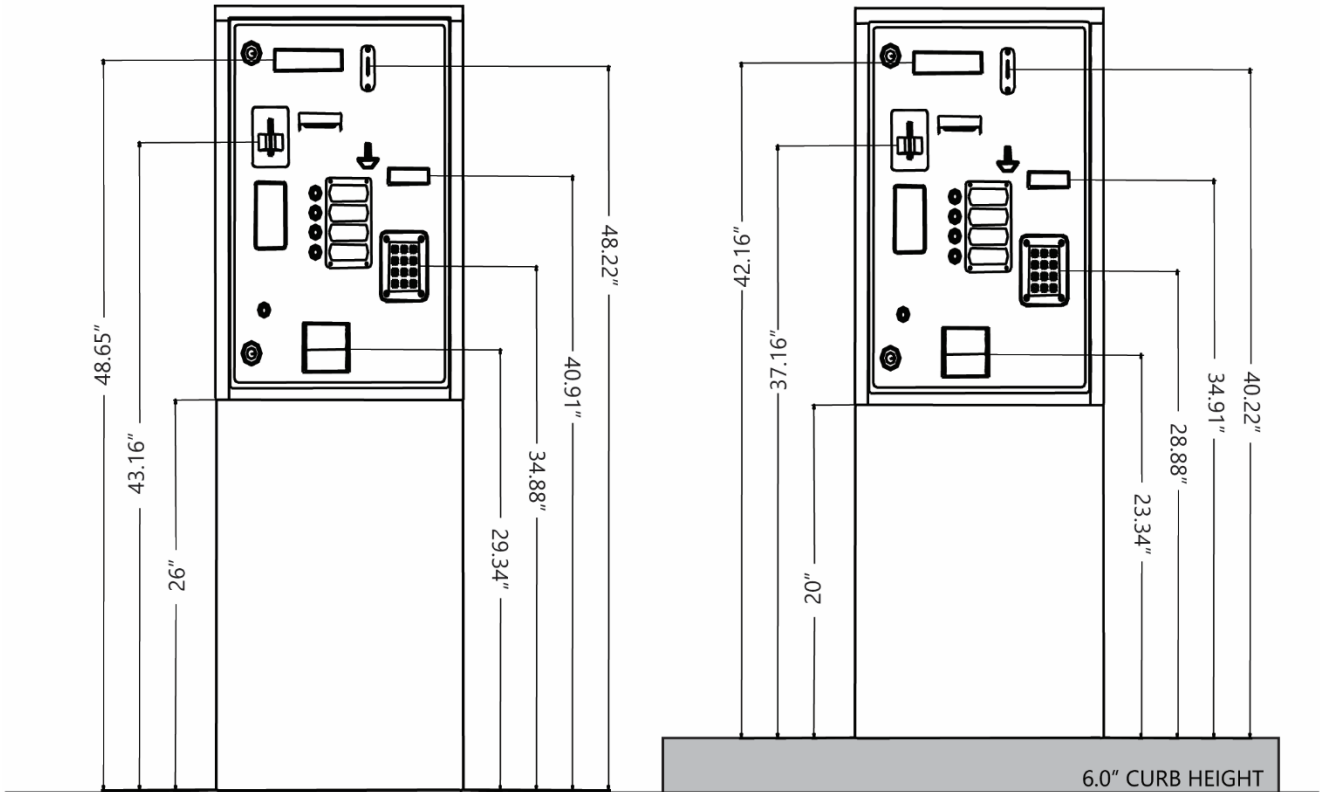

## BASE MOUNTING DIMENSIONAL INFO

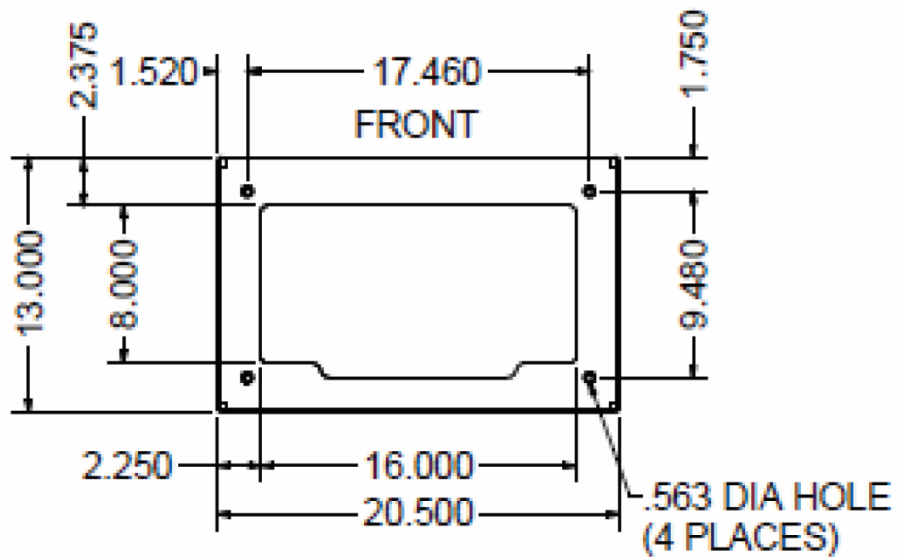

**RETROFIT GXP CABINET SPECIFICATIONS FOR ISLAND ENCLOSURES:**

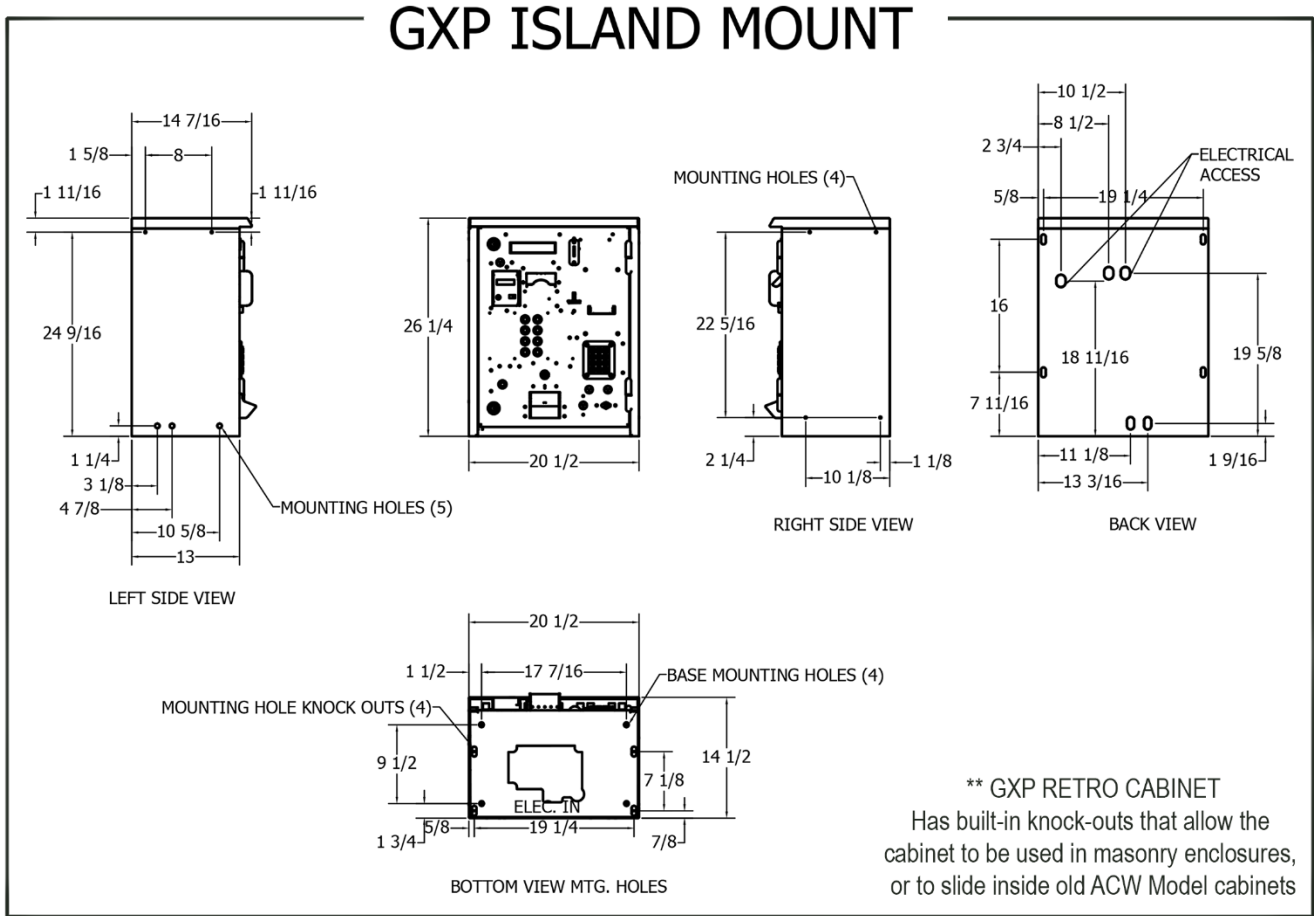

*The GXP RETROFIT CABINET has additional electrical knock-outs located on the top and back. These can be knocked out to make it easier to link existing electrical or communication cables into the GXP cabinet from various locations of the island enclosure. This Retro Cabinet is available by signifying that you plan to install in any metal or masonry enclosure.*

## SECTION 9: WASH BAY CONNECTIONS

The GXP uses a **Relay Board**, located on the back wall of the cabinet, for all car wash equipment connections. This Relay Board provides better feedback to the GXP's EF4 Control Board. Each wash selection wire has its indicator light that provides better feedback to the technician when troubleshooting.

At the top-center of the Relay Board is a 9-connection Terminal Block. Starting at the far-right side you have connections for Wash Selections 1-8, and a Common connection at the end on the far-left side of the Terminal Block. This block can be removed for easier wiring and then can be plugged back into the Relay Board.

**The Wash Equipment Connections Terminal Block has NORMALLY OPEN relay contacts to Common, and can accommodate 16-28 AWG wire. The Terminal Block has screws at the top and the wires are inserted in the front.**

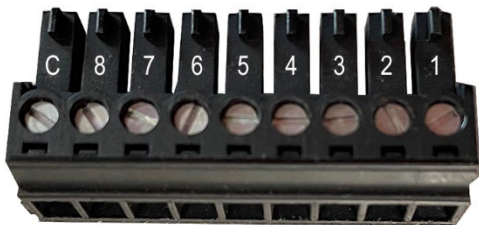

The Relay Board also has the connections for the **WASH BAY INHIBIT** and **WASH BAY FAULT** wire connections – located at the bottom-right of the board. These connections are also terminal blocks that can be removed, wired up and reinserted back into the Relay Board.

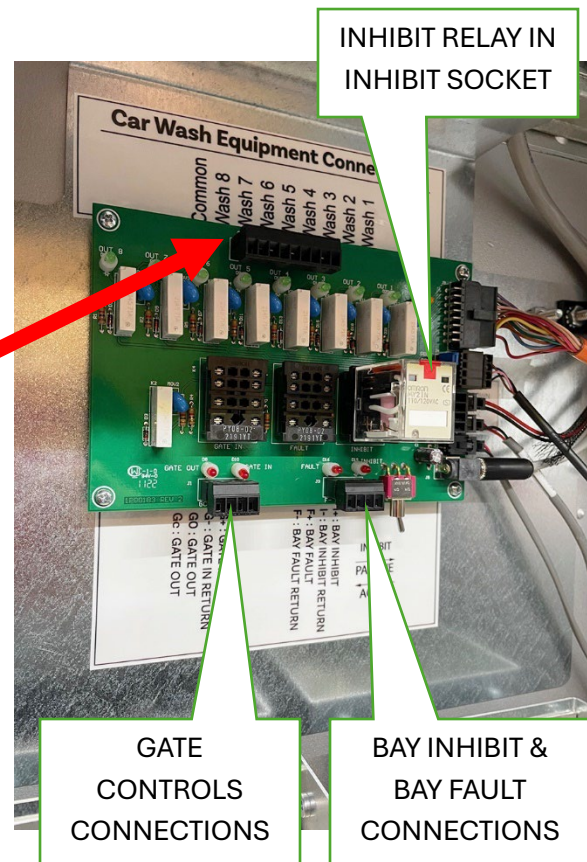

The **Wash Bay Inhibit (I+ and I-)** requires a Relay\* be inserted in the **Relay Inhibit Socket** located directly above the terminal connection (socket connection on the right).

The **Bay Fault Control (G0 and Gc)** requires a Relay\* be inserted in the **Relay Fault Socket** (socket connection in the middle). Both these connections can be made with 16-28 AWG wire run from the Car Wash Equipment.

**\* All GXP machines are shipped with a Relay Kit that includes 24VDC, 24VAC, and 120VAC relays for the Inhibit Signal. Please contact your car wash equipment supplier to determine the relay voltage required.**

If you are using a gate to control access to the wash bay, the **Gate Control Relay Terminal Block** connection is on the bottom-left of the Relay Board. The **GATE IN (G+ and G-)** Signal connection (located on the right side of the terminal block) requires a Relay\* inserted in the GATE IN socket – the left side socket connection located directly above the Terminal Block.

The **GATE OUT (G0 and Gc) Control** (locate don the left side of the terminal block) are NORMALLY OPEN relay contacts on the board and will accommodate 16-28 AWG wire.

On the right side of the Relay Board are direct connections from the EF4 Control Board (J9), 24VDC power connection (J5), and the connection from the Prox Jumper (next to J10). These connections are pre-wired from the factory.

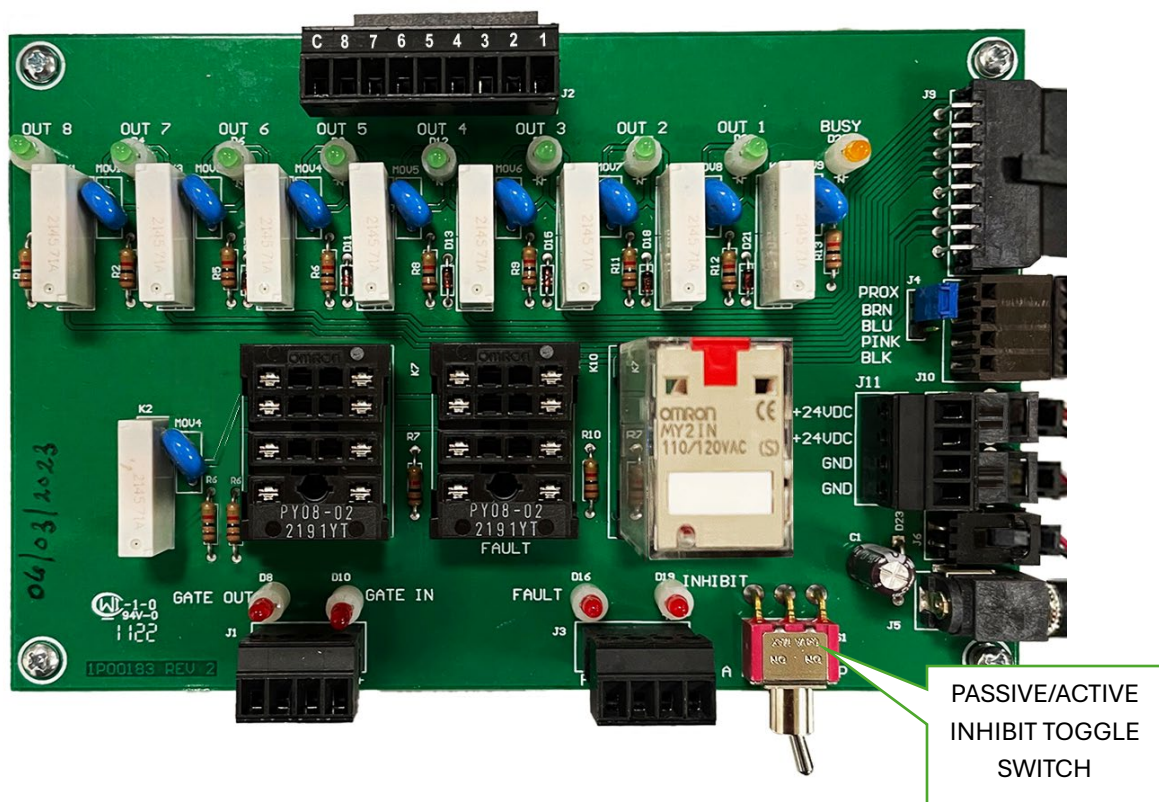

*In a standard 4-button wash selection machine – you would 4 wires connected to Terminals 1-4 and 1 wire connected to the Common of the Wash Equipment Connections terminal block at the top of the Relay Board. You would typically have 2 wires running to the Inhibit terminal block at the bottom, and a relay (of the proper voltage) plugged into the Inhibit Socket.*

The final component on the Relay Board is the **PASSIVE/ACTIVE INHIBIT TOGGLE SWITCH**, located on the bottom, to the right of the Inhibit Terminal Block. To determine if the Wash Bay Equipment requires an active or passive inhibit, if the **Inhibit Relay is ON at Idle = ACTIVE**; and if the **Inhibit Relay is OFF at Idle = PASSIVE** setting.

## SECTION 10: WASH BAY SIGNAL TIMING

The Wash Bay’s “wash signal” “wash bay inhibit signal”, and “bay fault signal” timing are shown in the following diagram. The gate timing is also shown at the bottom of the diagram.

### WASH BAY TIMING DIAGRAM

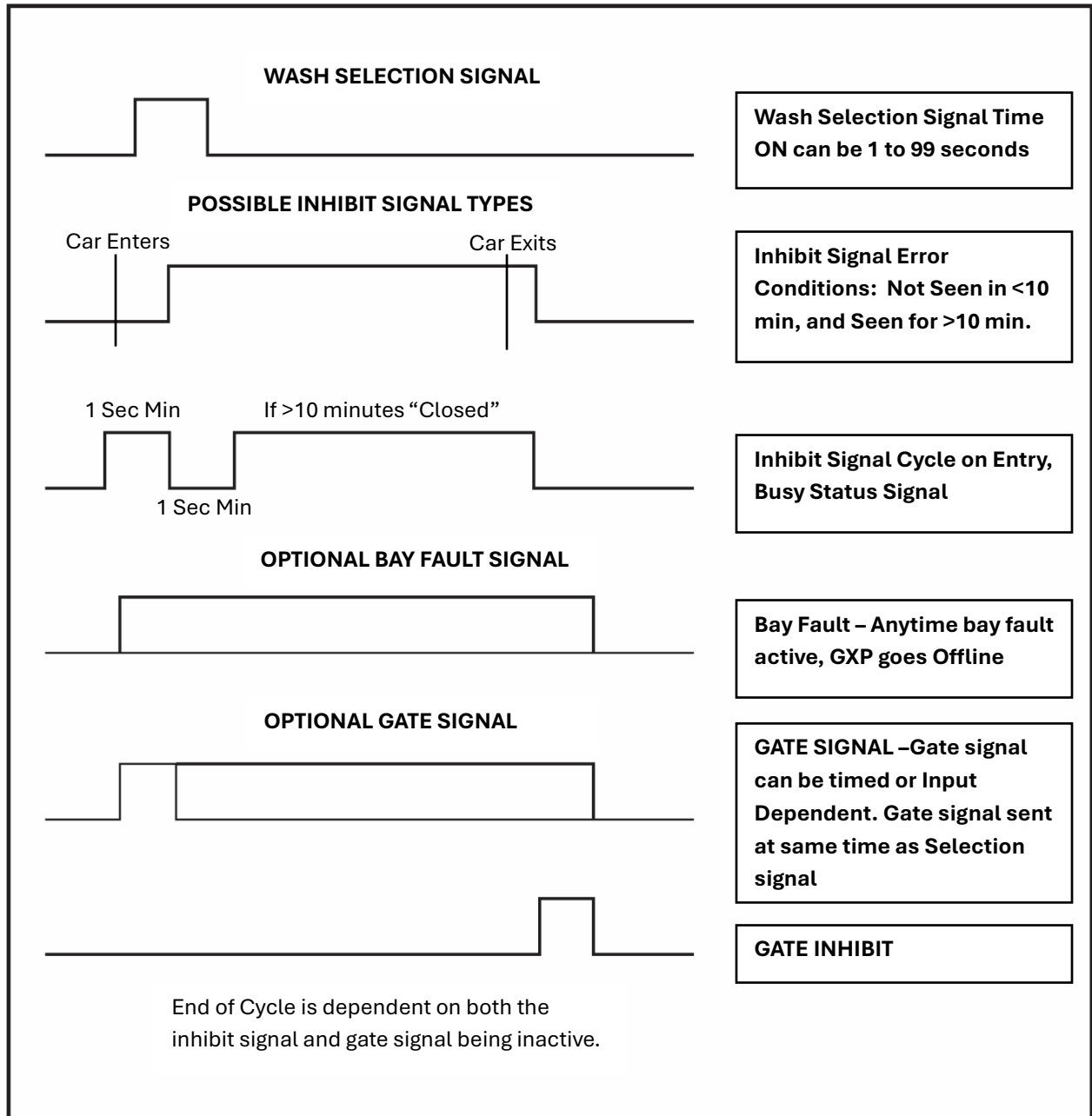

## SECTION 11: CHECK THE PROGRAMMING

### OVERVIEW OF OWNER INTERFACE

The *Owner Interface* features allow you to navigate through the various programming and reporting menus and reset the machine from error conditions. **The User Keypad (pin pad), User Selection (Wash Selection) Buttons and User LCD Display located on the front of the machine will be used to navigate through the various Main Menu features available.**

### OVERVIEW OF SETTINGS AND REPORTS

There are a variety of menu items available. Each main menu item will be either a SETTING or a REPORT menu. Settings are nothing more than system parameters that can be used to establish the machine behavior. Settings will typically relate to the hardware modules that you have purchased. For example, the “Bills Accepted Settings” menu relates to the bill acceptor and can be used to set the bill denominations to be accepted. As a result you can change the acceptance and security behaviors of the machine.

Reports allow you to view records that are stored in the machine. These records are useful for accounting and troubleshooting. See the sections titled “Report Menus” and “Settings Menus” for an explanation of the benefits of each. Each setting type or report type can be viewed (on user display) or printed on receipt printer (if the GXP is equipped with a Receipt & Audit Printer).

### Overview of Error Messages

If an error was detected in the machine the error condition will be the first thing displayed as you enter the Main Menu. If multiple errors have occurred the display will rotate through the errors. If you press the right or left arrow button you will be in the Main Menu. **Hint – you can also view the machine errors and events by accessing the Event Report menu item.** See the section of this manual titled Event Reports (Section 4.5.1) for more detail. For information regarding the errors, see the section of this manual titled Troubleshooting.

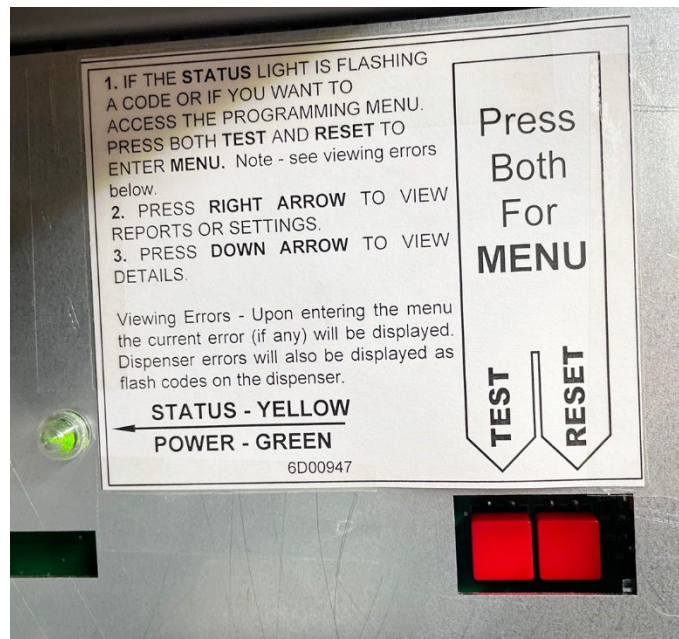

### ACCESSING THE MAIN MENU

Enter the Main Menu by **pressing both RED buttons simultaneous for at least 3 seconds** and then release them. See the decal (below) located on the main control panel for the location of the two red buttons.

**NOTE – you can return to the Main Menu screen at any time by pressing the CANCEL/REFUND button on the front of the machine door one or more times.** Once in the Main Menu you will either see the first *main menu* item or you will see one or more errors that were issued by the machine. If you see errors you will need to clear them. See the Troubleshooting section of this manual before proceeding.

Find the desired Setting or Report by pressing the RIGHT (forward) arrow button. To view the previous main menu, item simply press the LEFT (back) arrow. Once you have found the desired setting or report, you can then go *down* into the *Details List* for this item to view additional details related to it. Note – the main menu headings are in CAPS (all capitalized letters).

1. IF THE **STATUS** LIGHT IS FLASHING A CODE OR IF YOU WANT TO ACCESS THE PROGRAMMING MENU. PRESS BOTH **TEST** AND **RESET** TO ENTER **MENU**. Note - see viewing errors below.

2. PRESS **RIGHT ARROW** TO VIEW REPORTS OR SETTINGS.

3. PRESS **DOWN ARROW** TO VIEW DETAILS.

Viewing Errors - Upon entering the menu the current error (if any) will be displayed. Dispenser errors will also be displayed as flash codes on the dispenser.

← **STATUS - YELLOW**

**POWER - GREEN**

Press  
Both  
For  
**MENU**

TEST

RESET

6D00947

Exit by pressing the **Cancel/Refund** button on the front of the machine. The Cancel button is used to step back through the menus and then to exit the programming mode.



## MENU NAVIGATION

Navigating the menus in the EF-II controller is similar to navigating a spreadsheet. There are left and right arrow buttons to move you to the different columns and up and down arrows to take you to items to set or view. There are numeric buttons for entering numbers and text, a clear button to clear entries, and a Cancel button to pop you out of a menu.

## ARROW BUTTONS

The RIGHT / LEFT arrows are used to change from one main menu item or to pick one of the multiple settings. The UP / DOWN arrows are used to move through the list of available settings for each main menu item.

**Note the little dots next to the buttons as a reminder of the direction they take you.**

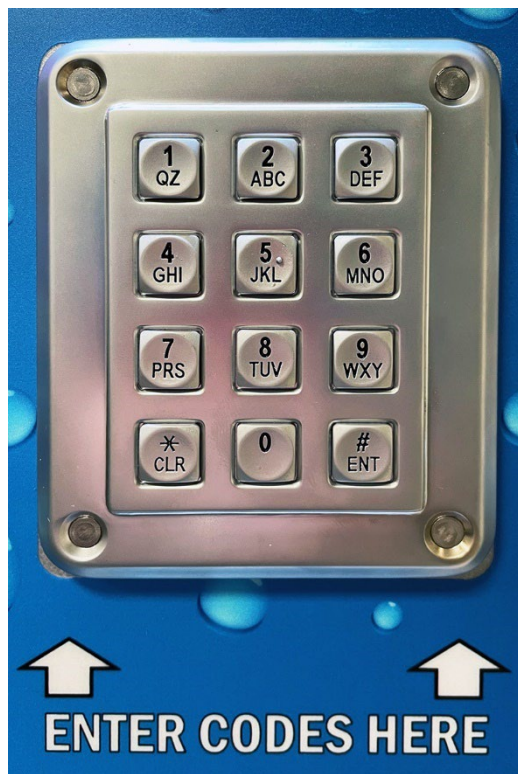
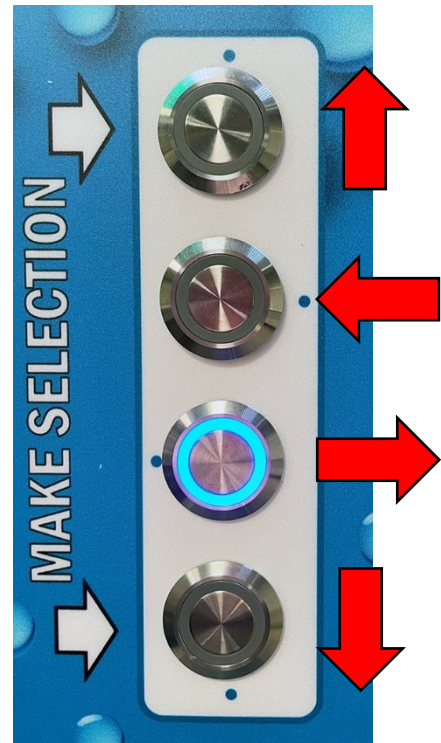

## NUMBER AND TEXT BUTTONS

The Alphabetical / Numeric buttons on the User Keypad are used for T9 numeric and text entries. Press the key multiple times to access other letters. Symbols (“\$-&\*<>...”) and Spaces are entered using the 0 and 1 buttons. The # symbol is entered using this button. It is important to note that the # button on the User Keypad is not used to enter the # symbol. Pressing the # button will display help information about the screen that is being displayed.

Numeric keys two through nine will cycle through the capitalized letters displayed on the key then the actual number then the non-capitalized letters. An example of the “2” key is A, B, C, 2, a, b, c, A, B etc. The “9” key is an exception in that it also has the letter “Z”.

The “0”key will display 0, period, ?, !, comma, @, double quote, dash, underscore, [ , ] , ( , ) , semi colon, colon, { , }.

The “1” key will display Q, Z, 1, q, z, \$, %, &, +, -, /, =, \*, <, >, #, |, ^.

## YES and NO BUTTONS

The “6” (MNO) button is used for ‘NO’ and the “9” (WXY) button is used for ‘YES’

## HELP BUTTON

The Help button “#/ENT” is used to display help relating to the menu feature you are looking at. It will also provide navigation tips to let you know how to move through the menu to see available choices. If at any time you are not sure what to do next just press the Help button.

Some help screens will not fit on a single display screen so it may be necessary to press the question-mark button (?) a second or third time in order to view the next help screen. The help screens include detailed information that pertains to the feature you are viewing or setting.

## CLEAR BUTTON

The Clear button “\*/CLR” is used to clear numeric entries or report totals.

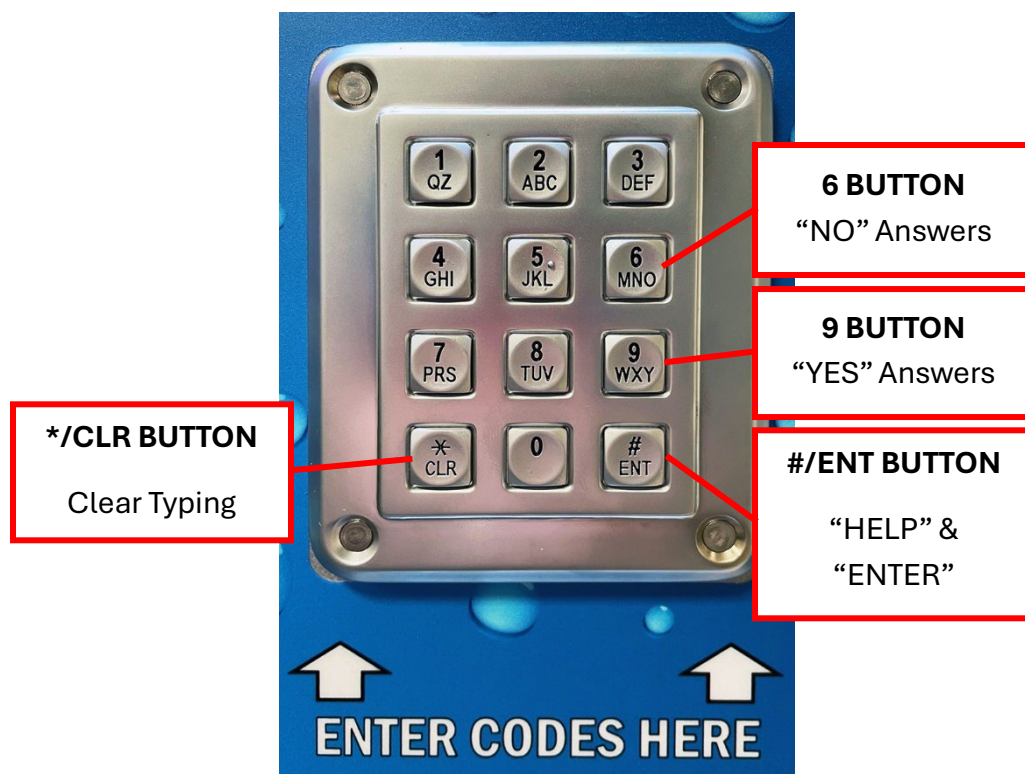

## DRILLING DOWN IN THE MENU

The UP and DOWN arrow buttons are used to navigate up and down through the list of details for a given *Feature Group*. You can move down in the list by pressing the DOWN arrow button. You can move up in the list by pressing the UP arrow button. When the end of the list is reached, the following message is displayed: “**end of list.**”

At this point you can press either the CANCEL or DOWN arrow button to get back to the top of the list. A feature group will wrap around. If you keep pressing the DOWN arrow will end up at the top. You can also press the UP arrow to come up from the bottom.

## MENU ENTRIES / QUESTIONS

**Here is how to identify which type of question is being asked and how to answer it:**

- **Yes or No questions.** These can be quickly identified because they end with a question mark “?” symbol. They are answered with a YES (“9” Button) or NO (“6” Button). These are typically used to enable or disable certain functions within the machine.
- **Numeric Entries.** These can be quickly identified because they always have a number in the entry even if the number is zero. These are answered by entering in a number from the user keypad. Pressing the clear button will zero the entry. These are typically used to set vend amounts, time delays, alarm inputs, etc.
- **Text Entries.** These can be quickly identified because a cursor (underline or underscore symbol) will be blinking under the first letter of the entry. These are answered using the letters associated with each number on the user keypad. These are typically used to allow you to create a receipt header or footer, enter a wash name, enter a promotion name, etc.
- **Multiple Choice Entries.** This type of question can be identified by the current selection having arrows on each side of the ←answer→. To see the list of available choices press the LEFT or RIGHT arrow button and the next choice is shown. **Once you have found your answer just press the DOWN button to proceed to the next question and the choice you were viewing will be accepted as the answer.**

# GXP PROGRAMMING MODE MENU

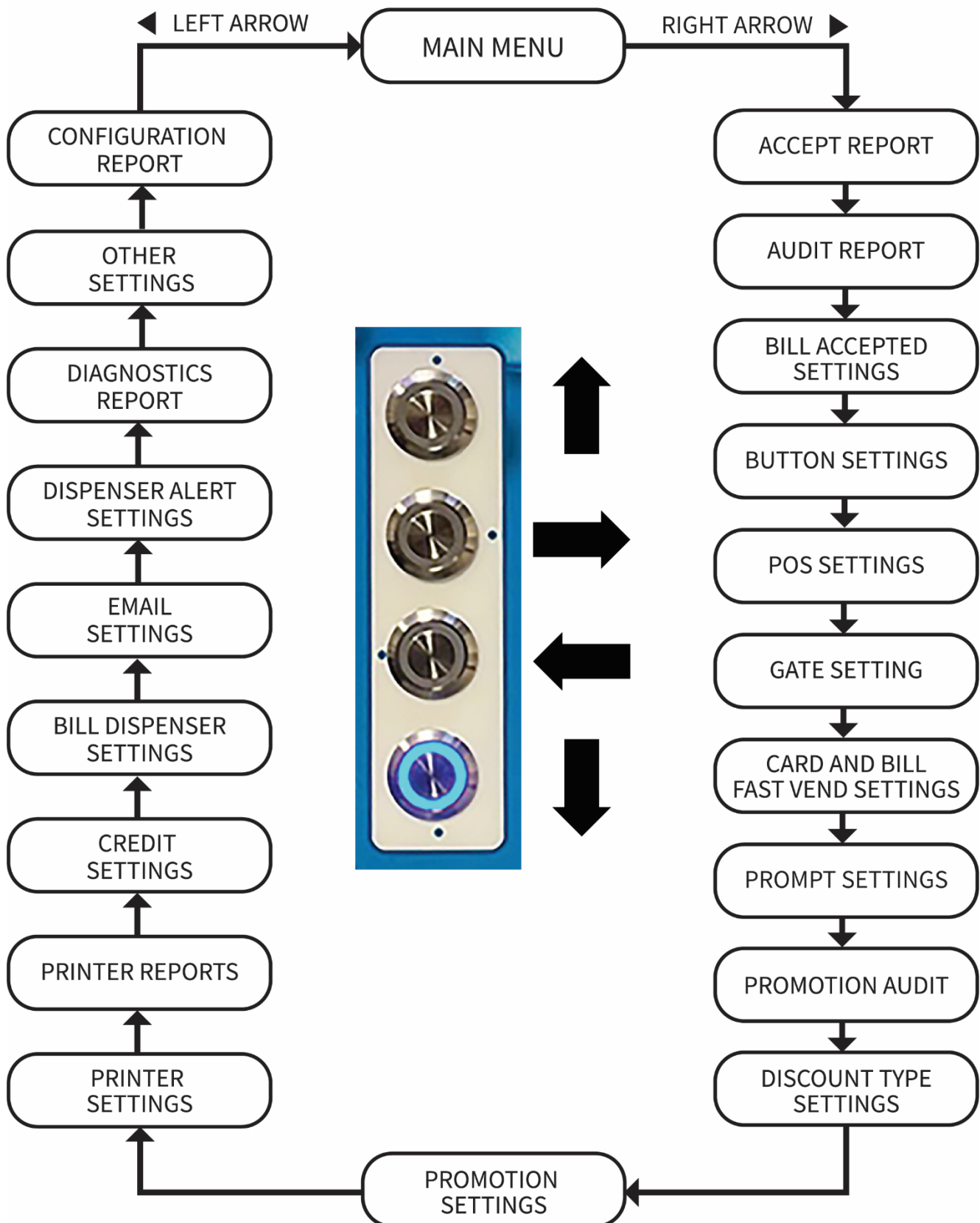

## SECTION 13: TESTING THE MACHINE

### CONTROLLER DIP SWITCH SETTINGS

Remove the cover panel of the GXP EF4 Control Board. To the left of the Red RESET/TEST BUTTONS, you see the Blue 8-Button DIP SWITCH controls. The following instructions relate to these switch settings:

**#1** – always “ON”. This sets the machine for the Slugbuster III coin acceptor. If machine is not equipped with a coin acceptor, this switch should be set to “OFF.”

**#2,3,4,5** – always “OFF”. These are not used.

**#6 – Input Test Mode:** “OFF” during normal operation. “ON” to allow the pay station inputs (bill acceptor, coin acceptor, buttons...) to be tested without sending the Wash Signal to the wash bay.

**#7 – Wash Bay Bypass Mode:** “OFF” during normal operation. “ON” to allow the pay station to be tested without sending the Wash Signal to the wash bay.

**#8 – Credit Card Demo Mode:** “OFF” during normal operation. “ON” to allow the pay station to accept credit cards without resulting in an actual credit transaction process.

### INPUT TEST MODE

This special test mode allows you to individually test each acceptor deposit or button press. This is particularly useful when troubleshooting an individual component like a button, button cable, bill acceptor or coin acceptor.

Any deposits will not be audited. If you deposit a particular coin or bill, the denomination will be shown on the user display.

### WASH BAY BYPASS MODE

The GXP can be tested without “firing” (sending the wash signal to the bay controller) the wash bay. This is useful for testing the machine after installation and if performing general troubleshooting on one of the acceptors.

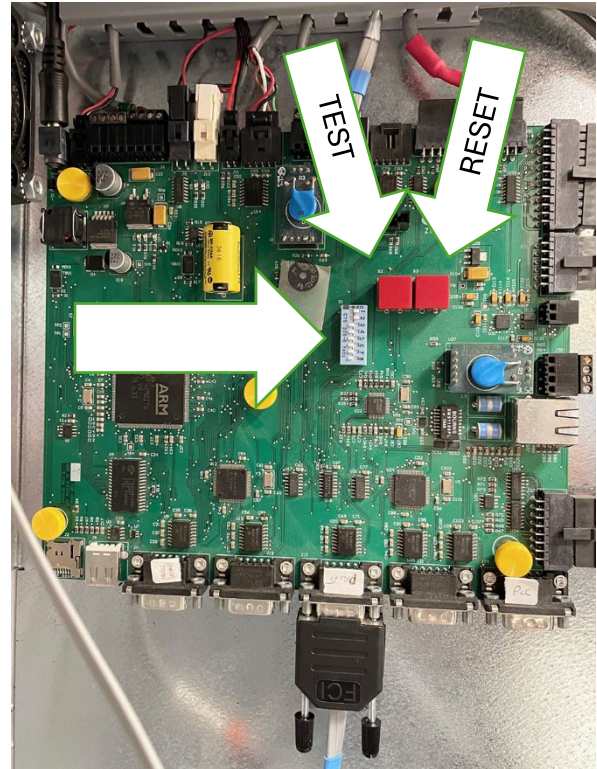

In this mode the Relay Board will not send the wash signals to the bay and it will not require the bay-in-use signal to be sent back from the car wash equipment.

To start this Test Mode set dip switch #7 to the “ON” position and press the RED “TEST” button next to the dip switches located to the LEFT of the two RED BUTTONS on the EF4 Control Board.

**The Test Mode will now activate for 5 minutes.**

When finished testing it is strongly recommended that the dip switch be returned to the “OFF” position and the machine be reset by pushing the RESET (Right Red Button).

**Hint: Set dip switch #7 & #8 to “ON” when testing the machine immediately following the machine installation.**

### **CREDIT CARD DEMO MODE:**

The Credit Card Reader can be set to bypass its communication settings, thereby allowing virtually any credit card for be used for testing without the card holders account being debited.

In this test mode the card, any card, is swiped and the amount to be debited is approved by the machine as opposed to being approved by the card processing company selected by the merchant. In essence the machine will issue free washes whenever any type of card is swiped and no debiting of the card holders account will occur.

To start this test mode, **set Dip Switch #8 to the “ON” position and press the red “TEST” button** located to the left of the RESET button. **This Test Mode will now activate for 5 minutes.**

When finished testing it is recommended that the dip switch be returned to the “OFF” position and the machine be reset by pressing the red button on the right next to the dip switches.

**Note – when entering this mode you will hear two long beeps from the machine to confirm this mode is activated and the user display will show that you are in this mode.**

These settings are indicated on the decal on the inside of the GXP EF4 Control Board cover panel.

## **SECTION 14: TROUBLESHOOTING**

### **RESTORING FACTORY DEFAULTS**

- You can restore the factory default settings for all numerical entries.
- Text entries will remain intact after restoring factory defaults.

To restore the defaults drill down into the “CONFIGURATION REPORT” until you come to the last entry - “end of list”. While at this point, press the CLEAR button (CLR on User Keypad) and be prompted to answer “YES” (BUTTON 9) to “clear the defaults?”

**IMPORTANT NOTE:** You should check every setting after restoring the factory defaults.

## INHIBIT RELAY STATUS

If the Car Wash Controller momentarily turns the relay OFF after the end of a wash cycle, set the toggle switch on the GXP to **Active**. If the Car Wash Controller turns the relay ON momentarily after the end of a wash cycle, set the toggle switch on the GXP to **Passive**.

## INSTALLATION TROUBLESHOOTING

- ✓ Printout or written list of the “machine configuration”.  
See the Machine Configuration Report in the Main Menu.
- ✓ Have Manufacturer and Model of the Wash Bay available.
- ✓ Run the Internal Testing outlined in the “Test The Machine” section of this manual.
- ✓ CHECK ETHERNET TERMINATION (if using Ethernet connection): The Ethernet connections are “Normal” (straight through) connections from one cable end to the other. It does not matter which RJ45 (at end of cable) plugs into a particular device.
- ✓ For additional questions, contact the Standard Change Makers Service Dept.

Monday – Friday      8:30 AM to 4:00 PM (Eastern)

800-968-6955 – Option 2, Option 4

EMAIL: [gxp@standardchange.com](mailto:gxp@standardchange.com)

## CREDIT CARD SETTINGS

Access the Main Menu in the GXP. Step through the Menu selections by pressing RIGHT ARROW until you find the “CREDIT SETTINGS” menu. Press the DOWN ARROW to view “card system” settings. Press RIGHT ARROW to be sure this setting is “MDB”.

Regardless of whether you are using Nayax, Cryptopay, ePort, or Monex – they will all use the MDB setting.

After setting this, press the REST/CANCEL button (on the front of the door), to scroll back up to Main Menus level CREDIT SETTINGS, then press RIGHT ARROW button until you get to CONFIGURATION REPORT, press DOWN ARROW to REPORT DATA, and press RIGHT ARROW to go through the settings and make sure you see the Credit Card Reader is in the configuration.

You can exit to the MAIN MENU when finished.

# GUARDIAN XP (GXP)

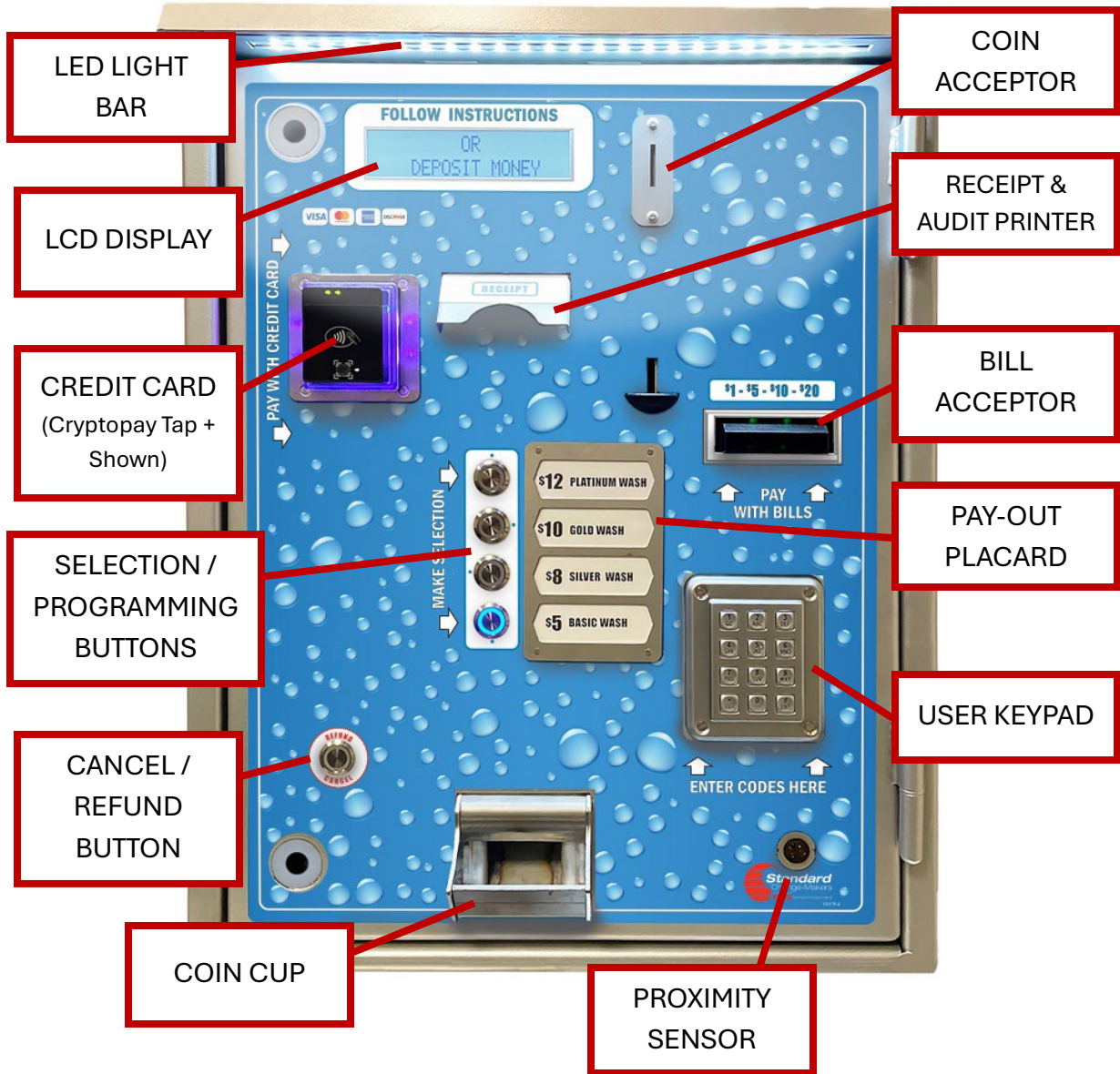

## INSIDE THE GXP (DOOR VIEW)

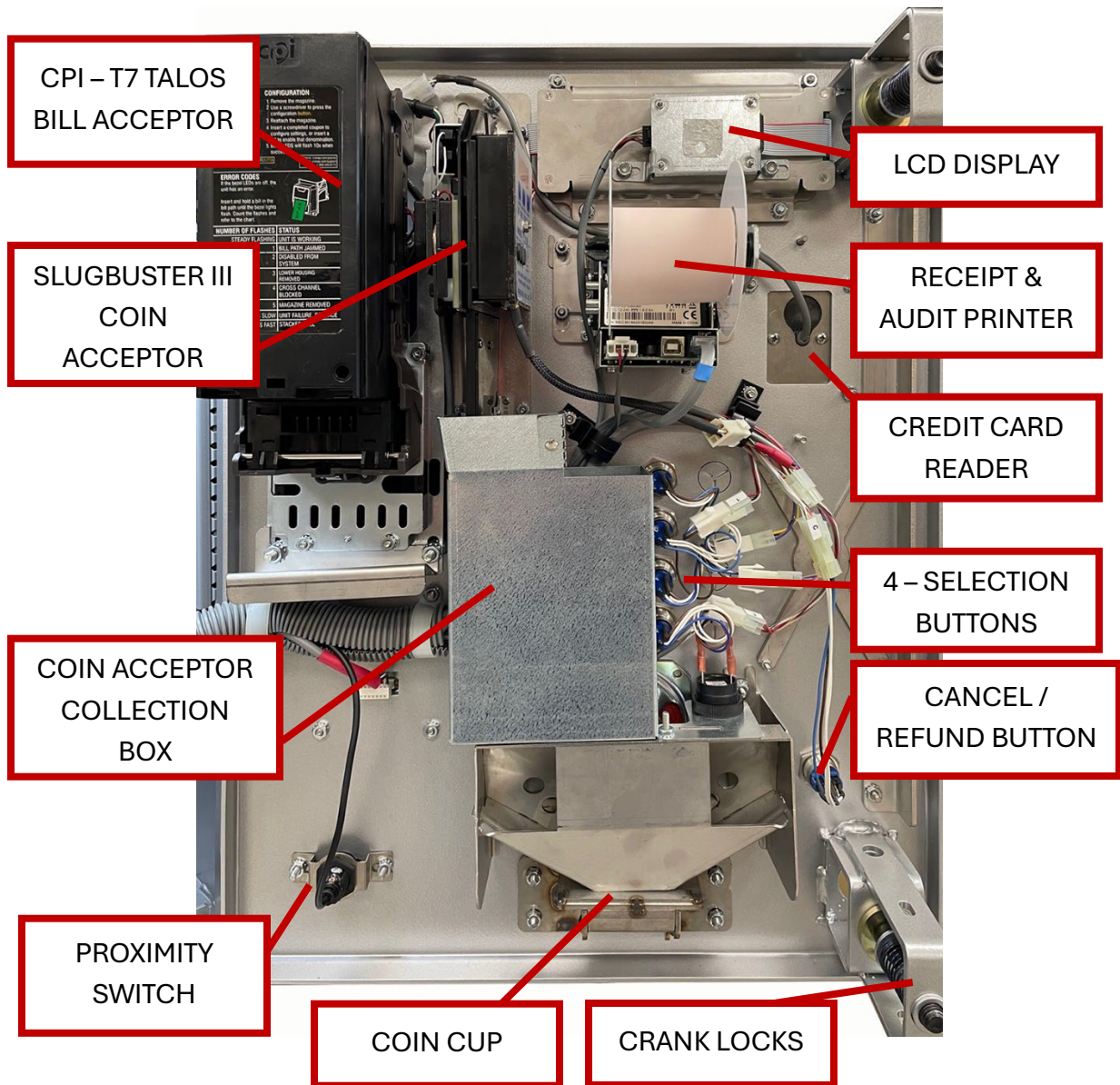

### INSIDE THE GXP (CABINET VIEW)

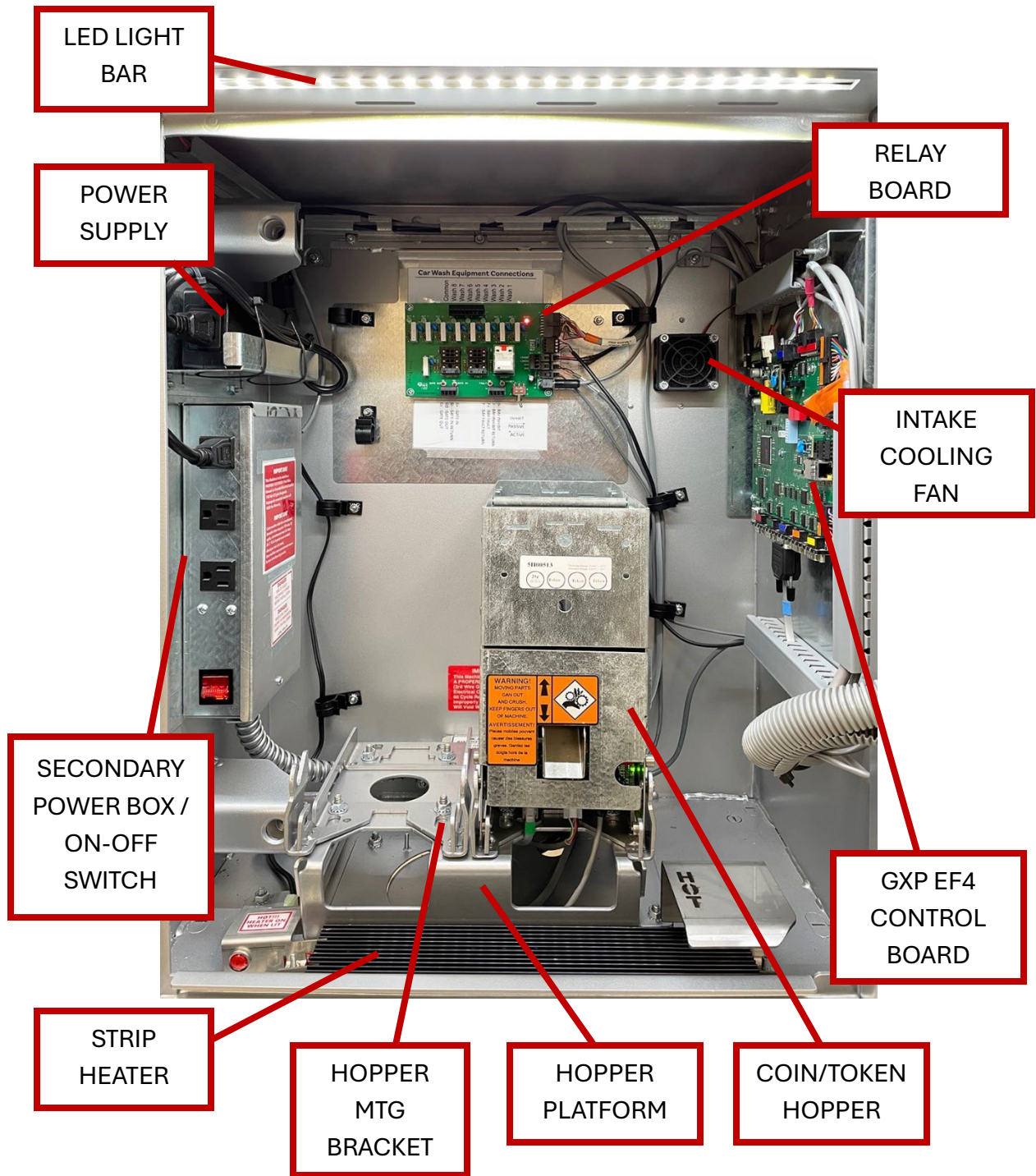

\*\* MAIN POWER JUNCTION BOX LOCATED BEHIND HOPPER PLATFORM (NOT SEEN ABOVE)

## COUPON SECTIONS CONTINUED

### SECTION 6 - ACCEPTANCE MODE Non-Recycler Mode Only

**Mode 0:** Factory default. No acceptance modes active.

**Mode 1\*:** If fraud is detected the validator enters an out-of-service time-out, the stacker plate extends into the bill magazine and the bezel LEDs flash. If any sensors are blocked, the time-out persists until the jam is cleared.

**Mode 2\*:** All the features of Mode 1, plus the stacker plate extends into the bill magazine when idle.

**Mode 3\*:** All the features of Mode 2, but more aggressive. It may increase jams and service calls. Mode 3 is recommended for temporary use only.

\*Requires power



## Talos™ Coupon Guide

Carefully cut coupon from this page or make one copy of this coupon.

Copies are usable if made on a standard, carbon-based copier. Make one copy of the original at a time, as copiers tend to reduce the size of the coupon when multiple copies are made.

Fill out the coupon using a #2 (HB) pencil. Fill in one block for each line. Do not mark the back of the coupon.

Note that Talos units are preconfigured with the following options enabled:

- Accept \$1 bills
- Four way accept

### Initiating Coupon Mode on a Talos without a Recycler

1. Remove the bill magazine
2. Use a pencil or a screwdriver to press this button to enter configuration mode, then reattach the bill magazine to initiate Coupon mode:

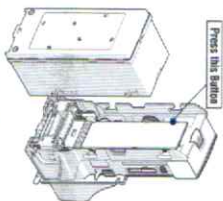

### Initiating Coupon Mode on a Talos with a Recycler

1. Hold the Mode button on the recycler to enter the menu
2. Press Mode to cycle through the options, and stop when CP is displayed
3. Press Select to initiate Coupon mode

### When coupon mode is activated, the bezel lights will rapidly flash

1. Insert a completed configuration coupon
2. Watch the bezel LEDs and count the flashes when the configuration coupon is returned
3. Use this chart to confirm successful programming:

Flashes	Meaning
10	Configuration coupon accepted and unit successfully programmed.
1 - 5	Coupon rejected. Number of flashes corresponds to the coupon section that was improperly filled out. Try again.
7	Coupon not read. Confirm the coupon correct and try again.

This space is left intentionally blank.

## FREE VEND COUPONS AND BILL PROGRAMMING

Follow the same process to program the Talos with bills or free vend coupons, but note that the LED codes are slightly different:

Flashes	Meaning
10	The bill or vend coupon has been enabled successfully
7	The bill validator was unable to read the bill or vend coupon. Try again.
3	The bill or vend coupon has been disabled

### PROGRAMMING WITH CPI SYNQ

1. Open the Simplifi app on your mobile device and tap the Synq your Talos is connected to



2. Tap Configuration



3. Make your selections and tap Update

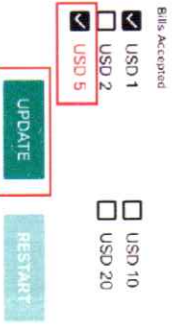

4. Tap OK on the prompt, then tap Restart to save changes



### OTHER DOCUMENTATION

All support documentation, including a downloadable copy of this coupon, can be found at [Cranepi.com/support](http://Cranepi.com/support).



Log in Tap Support Add a Product Then Use the filters or scroll to find Talos View Downloads Then Choose your Document

## COUPON SECTIONS

### SECTION 1 - BILL WAYS

- 1 - Face up in one direction (green seal first)
- 2 - Face up in either direction
- 4 - Face up or down in either direction

### SECTION 2 - BILL ENABLES

Fill in on or off to enable or disable a bill.

### SECTION 3 - MDB INTERFACE Recycler Only

- L2 - MDB Level 2. Use when accepting \$20
- L3 - MDB Level 3. Use when recycling \$1, unless accepting \$20
- RE - Stand alone Recycler Mode
- AU - Auto-Interface. Recycler determines setting.

### SECTION 4 - RECYCLED BILL

Recycler Only - Determines which bill is sent to the recycler.

### SECTION 5 - RECYCLED BILL Recycler Only

Yes - Limits high value notes as inventory depletes

No - Accepts all enabled notes

### SECTION 6 - ACCEPTANCE MODE

Details on next page

Print actual size

66mm

T2700(R) Coupon

Sections 1 & 2 must be filled in

Bill ways accepted

1  1  2  4

Bill enables  on  off

2 \$1  \$2  \$5  \$10  \$20

Sections 3-5 for Recycler Models

3 L2  L3  RE  Au

4 Recycled Bill \$1  \$5  \$10

5 Accept inhibit ON  OFF

156mm

Section 6 for Non-Recycler Models

Acceptance mode (section is optional)

6 Mode 0  Mode 1  Mode 2  Mode 3



Cut carefully on the dotted line. The coupon should be the same size as an American bill when complete.

# Slugbuster® III

## Technical Information – Coin Installation

## Hook-up and Wiring

## Programming

### Coin Installation

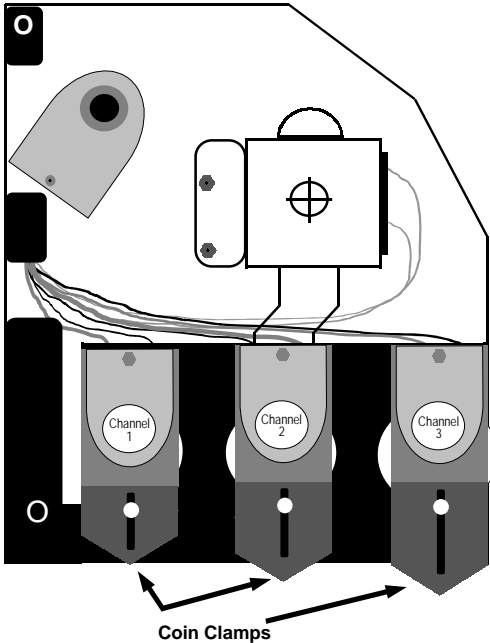

#### To Install Sample Coins:

1. Place the unit with sample coin holders facing up.

2. Loosen the three thumb screws that secure the coin clamps.

*Note: The solid-state technology of Slugbuster III requires sample coins to function properly, specifically quarter and dollar coins. You must insert a different sample coin in each of the three channels, whether you accept them or not.*

3. Insert 3 sample coins from the rear, right side of the unit. Use each consecutive coin to push the next coin over, until the first coin is in the left coin holder.

4. Line up each coin with the coin clamp and firmly push the clamps up into the coils to seat the coins in proper position.

5. Recommended installation of sample coins:

Channel 1 – Quarter

Channel 2 – Token

Channel 3 – Dollar coin

Your Slugbuster is now ready to install and program.

**Do not tamper with screws or nuts covered with blue sealer.**

These are factory-set adjustments and tampering with them voids your warranty.

\* Maximum token size for use in the United States is 1.125"

\* **Not all coins are compatible with Slugbuster III.**  
Please contact us for details at 800-752-0762

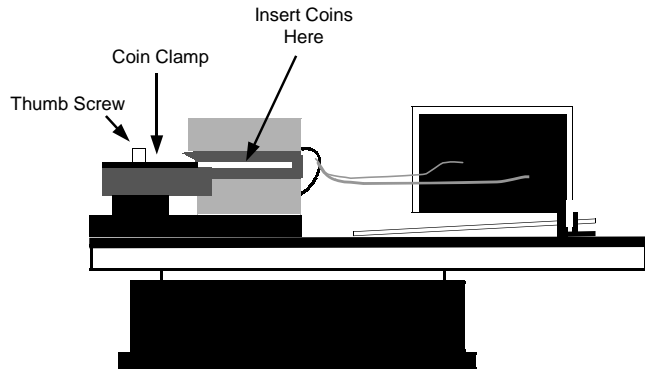

Right Side View

### Hook-up and Wiring

#### Color-coded power cords make hook-up easy

Single or Dual  
Coin/Token

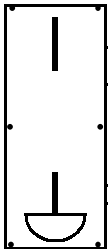

**Blue Wire:** 8-volt DC out-going pulse for timer coin switch; provides direct hook-up for most timers (please call for compatibility details)

**Yellow Wire:** "Hot" 24-volt AC supply to Slugbuster

**Black Wire:** Common/ground 24-volt AC supply to Slugbuster

**Purple Wire:** 24-volt AC out-going pulse for optional coin counter

Please contact us with any questions

**Parker Engineering & Manufacturing**

[www.slugbuster.com](http://www.slugbuster.com)

**Phone:** 616-784-6500 or 800-752-0762

11 North Park Street NE, Grand Rapids MI 49544

**Email:** [info@slugbuster.com](mailto:info@slugbuster.com)

**Fax:** 616-784-6501

## Programming

### To Program Your Slugbuster III:

1. **First, set the value of the smallest coin to be accepted.** Push and hold the 'Program' button until the display reads **A .25**. Push the 'advance' or 'decrease' button to change the coin value. Ex: If a quarter is the smallest coin you will accept, set the value to 'A .25'.
2. **Next, set the value of coin Channel 1.** Push the 'Program' button one time, so the display reads **b .25**. Use the 'advance' or 'decrease' button to change the coin value. The value will be changed in increments according to the smallest coin accepted, as set in step 1.
3. **Set the value of coin Channel 2.** Push the 'Program' button one time, so the display reads **C 2.00**. Use the 'advance' or 'decrease' button to change the coin value for Channel 2. The value will be changed in increments according to the smallest coin accepted, as set in step 1.
4. **Set the value of coin Channel 3.** Push the 'Program' button once again, so the display reads **d 1.00**. Use the 'advance' or 'decrease' button to change the value for Channel 3. The value will be changed in increments according to the smallest coin accepted, as set in step 1.
5. Push and hold the 'Program' button until a flashing dot appears in the lower center of the display. Your Slugbuster is now ready to accept coins.

### Viewing and Resetting Audit Channels

To review the audit channels, press and hold the 'Program' button until the display reads A .25, as in step 1 above. Continue pushing the 'Program' button and cycle through the display, past d 1.00.

- The display will then flash CH-1 and read the number of coins accepted on Channel 1.
- Push 'Program' once more and the display will flash CH-2 and read the number of coins accepted on Channel 2.
- Push 'Program' again and the display will flash CH-3 and read the number of coins accepted on Channel 3.

To reset the audit channels, press and hold the 'advance/delete' button until the display reads zero while viewing each channel's audit as described above.

## Turning a Channel Off / Adjusting Sensitivity

### Turning a Channel Off

During programming, press the 'advance/delete' button until the display reads OFF for the desired channel. The unit will now reject the coin; however, you must leave the sample coin in the unit.

**DO NOT use the sensitivity adjustment to turn a channel off. Sensitivity potentiometers should only be adjusted as a last resort for acceptance problems.**

Slugbuster must have sample coins installed in all three Channels, whether or not they are to be accepted. Do not use the same sample coin in more than one Channel.

Channel 1 – Quarter      Channel 2 – Token or Nickel      Channel 3 – Dollar coin (Susan B. Anthony or Golden Dollar)

### Adjusting Sensitivity

Sensitivity adjustment potentiometers (pots) are factory set for use with US Quarters, 85/15 Tokens and US Dollar Coins. If it is necessary to adjust pots:

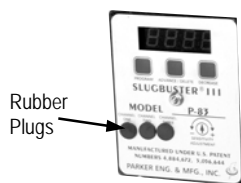

1. Remove the rubber plug for the desired channel
2. Using a small plastic stylus, turn the pot.  
The safe range for adjustment is between '10 and 2 o'clock'  
Do not adjust the pot beyond these ranges to avoid credit and acceptance problems.
3. Replace the rubber plug.

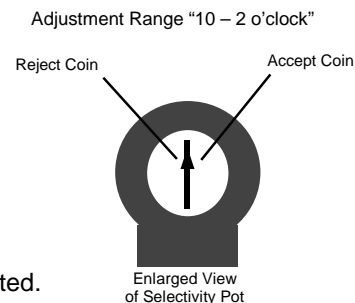

If the unit is accepting incorrect coins, turn the pot counter-clockwise on the channel being credited.  
If the unit is rejecting good coins, turn the pot clockwise for the channel not accepting coins.

## Cleaning Your Slugbuster

Clean your Slugbuster with a soft cloth and warm water. DO NOT use oil or other corrosive liquids.

**Please contact us with any questions**

**Parker Engineering & Manufacturing**  
**www.slugbuster.com**  
**Phone:** 616-784-6500 or 800-752-0762

11 North Park Street NE, Grand Rapids MI 49544  
**Email:** info@slugbuster.com  
**Fax:** 616-784-6501

Rev 2/05

Page 2 of 2

## **SERVICE & SUPPORT CENTER**



### **Standard Change-Makers**

Division of RKU Standard Incorporated  
3130 North Mitthoeffer Road  
Indianapolis, Indiana 46235-2400  
**800-968-6955 | 317-899-6966**  
[gxp@standardchange.com](mailto:gxp@standardchange.com)  
[www.standardchange.com](http://www.standardchange.com)

### **IMPORTANT NOTE:**

It is very important that you be at the machine when calling for service support. The technician that assists you will want you to step through the programming mode to provide feedback about settings within the machine. Being at the machine to provide immediate feedback is integral to the accuracy of the support process.

### **ALL RETURNS FOR REPAIR / REPLACEMENT REQUIRE AN RMA NUMBER**

To receive a Return Materials Authorization Number (RMA) please contact the factory by calling 1-800-968-6955 - Ext. 101, or emailing [rma@standardchange.com](mailto:rma@standardchange.com)

